

900 SERIES MOUNTING BRACKET INSTALLATION INSTRUCTIONS

9MBAXX - 900 Series Mounting Bracket Adapter for 700 Series Cutout

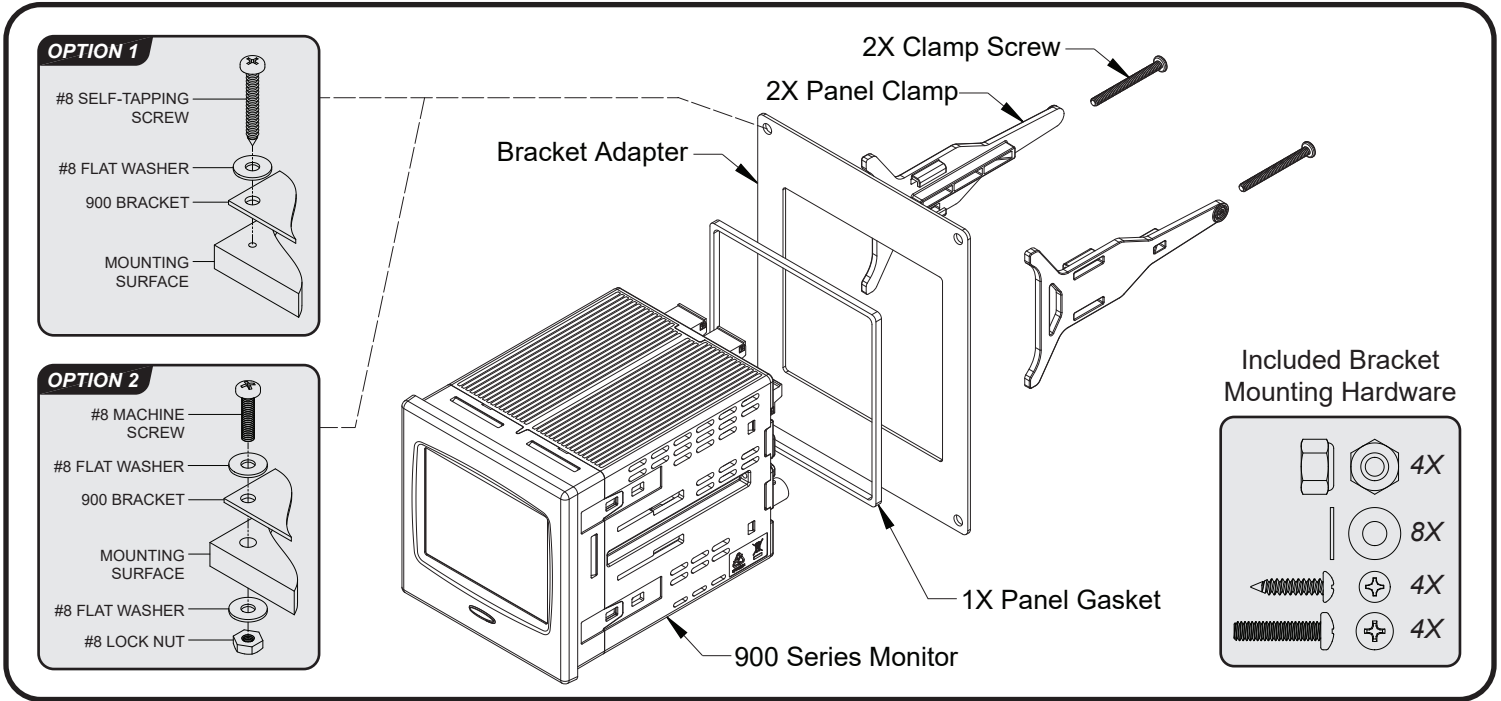

- 1 Pre-drill holes using bracket as a template, or provided dimensions.
- 2 Mounting holes may be enlarged to customer's desired size.
- 3 Install bracket using the provided hardware or substitute for your application*.

* If adapter bracket is installed in an ingress protected application, it will be necessary to provide a seal such as RTV between bracket and mounting surface.

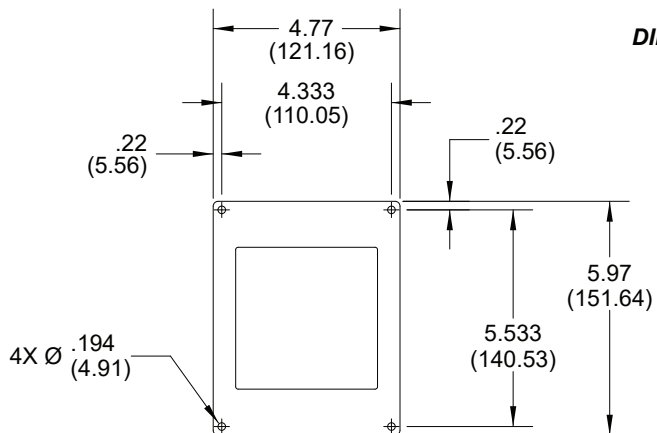

**NOT TO SCALE
DIMENSIONS IN INCHES
(MILLIMETERS)**

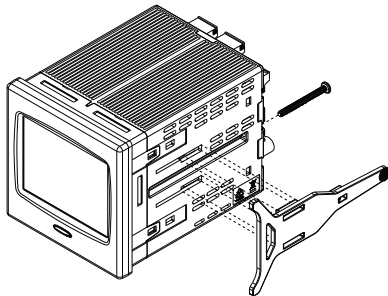

- 4 Ensure that panel gasket is pre-installed behind bezel.
- 5 Slide unit into bracket adapter.
- 6 Install clamps into guides and slide forward.
- 7 Install and rotate screws until clamp makes contact with panel.

- 8 Continue tightening screws until gasket is evenly compressed to 50% of its original thickness.

