











# Myron L<sup>®</sup> Company – Ultrameter III<sup>™</sup> 9P Quick Start Guide

Handheld Conductivity, Resistivity, TDS, pH, ORP, Hardness, Alkalinity, LSI, Free Chlorine Equivalent (FC<sup>E</sup>), and Temperature Meter

This Quick Start Guide is for the Myron L<sup>®</sup> Company Ultrameter III Model 9P. Download the full 9P Operation Manual (P/N 9POM) from [www.myronl.com](http://www.myronl.com) to get more detailed instructions for taking measurements (including Alkalinity, Hardness, LSI calculations, and FC<sup>E</sup>), storing or recalling measurements, changing instrument settings, measurement techniques, maintenance procedures, calibration procedures, Troubleshooting Guide and FACTORY CAL reset.

## QUICK REFERENCE INSTRUCTIONS

-        Press and release any one of these buttons to turn on the 9P and begin taking measurements.
- Press  to calculate LSI.
-  Press and release the CAL/MCLR button to calibrate (CAL) the active measurement parameter or press and hold to clear displayed memory location (MCLR).
-  Press and release to store (MS) a measurement or move upward on the list of stored measurements (Location 1 to 100) while in memory recall mode.
-  Press and release to view the most recent stored measurements or move downward on the list of stored measurements (Location 100 to 1). Also used to enter Settings Mode.

## 9P FEATURES

1. **TEMPERATURE SENSOR** – Houses thermistor for making temperature measurements.
2. **CONDUCTIVITY CELL** – Contains electrodes that generate a flux field in defined area for all measurements except pH, ORP, and FC<sup>E</sup>.
3. **pH/ORP SENSOR** (user replaceable) – Measures test sample's pH, ORP, and Free Chlorine Equivalent (FC<sup>E</sup>).
4. **pH/ORP SENSOR PROTECTIVE CAP** – Snaps in place to protect the pH/ORP sensor when not in use and seals in the sensor storage solution.
5. **LCD DISPLAY** – Displays measurements, units of measure, active measurement mode, current solution mode setting, low battery warning (LOBATT), titration prompts, and other information (see below).
6. **MEASUREMENT KEYS** – Press and release any one of these to turn on the 9P and begin taking measurements.
7. **FUNCTION KEYS** – Press and release to store the current measurement (MS) or recall a stored measurement (MR). Also used to move between memory locations and to select various mode settings.
8. **CAL/MEMORY CLEAR KEY** – Use to calibrate (CAL) the active measurement parameter, enter or clear the contents of the currently displayed memory location (MCLR).
9. **BLUETOOTH SYMBOL** – Indicates that this Ultrameter III 9P is equipped with Myron L<sup>®</sup> Company's optional wireless transceiver for wireless data download.
10. **CELL EXTENDER** – Extends cell cup and holds sample and reagents during Alkalinity and Hardness measurements.
11. **PLUNGER** – Used to create proper cell cup volume of liquid during Alkalinity and Hardness measurements.
12. **CELL EXTENDER CAP** – Seals cell extender while mixing sample and reagents during Alkalinity and Hardness measurements.

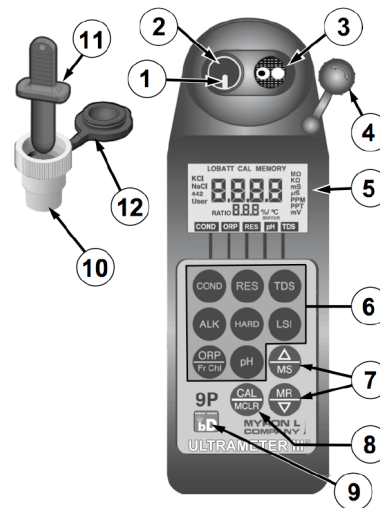

## LCD DISPLAY

1. **MAIN VALUE DISPLAY** – Displays the current measurement value and settings menu information. During Alkalinity & Hardness titrations, prompts appear here at various stages of the process.
2. **UNITS OF MEASURE ICONS** – Appropriate icon is displayed to indicate the unit of measure for the current measurement.

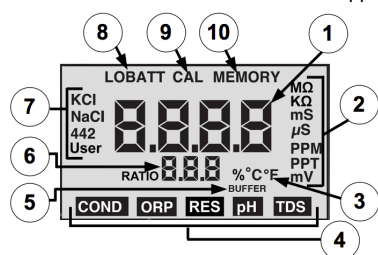

3. **TEMPERATURE UNITS OF MEASURE** – Displays °C (Celsius) or °F (Fahrenheit) based on setting selected for Temperature readings.
4. **MEASUREMENT ICONS** – Appropriate icon is displayed to indicate what type of measurement is being made.
5. **BUFFER ICON** – Appears when the 9P is in pH Calibration mode to indicate that the instrument is expecting a pH buffer solution.
6. **TEMPERATURE DISPLAY** – Displays the temperature of the sample solution, memory location number (1 to 100) or buffer during pH calibration.
7. **SOLUTION MODE ICONS** – Appropriate icon is displayed to indicate the current solution temperature compensation mode setting for Conductivity, Resistivity and TDS measurements.
8. **LOBATT ICON** – Appears when the 9P's battery requires replacement.

9. **CAL ICON** – Is displayed when the 9P is in Calibration mode.
10. **MEMORY ICON** – Is displayed to indicate that the values and icons being displayed are for a measurement stored in the 9P's memory (NOT a live measurement).

## OPERATING INSTRUCTIONS

### DEFAULT SETTINGS:

- **Temperature Units:** °C (Temperature is displayed in Degrees Celsius)
- **Solution Modes:** Conductivity – KCl, Resistivity – NaCl, TDS – 442<sup>™</sup>









**MEASUREMENT SETUP:** Before you take a reading, make sure the 9P is clean, calibrated, and if measuring COND or TDS, that the desired solution mode has been selected (See Section II, Solution Mode Selection, below). The sample solution must also be within the specified range.

For pH, ORP and FC<sup>E</sup> measurements both the pH/ORP sensor well and conductivity cell cup must be rinsed and filled with sample solution.

For greatest accuracy, resistivity, ORP, and FC<sup>E</sup> measurements should be taken from a continuous flow of sample solution.

### I. MEASUREMENT

1. Rinse the sensor well and/or cell cup 3 times with sample to be measured.
2. Fill the sensor well and/or cell cup with fresh test sample.
3. Press the appropriate Measurement Key:

-  COND: Measures Conductivity
-  TDS: Measures Total Dissolved Solids
-  RES: Measures Resistivity
-  ORP/FC: Measures ORP or Free Chlorine Equivalent (FC<sup>E</sup>)\*
-  pH: Measures pH
-   Press one of these to begin an Alkalinity\* or Hardness\* titration.
-  LSI: Press to calculate LSI\*. Uses stored or hypothetical Alkalinity and Hardness data.

\* For complete instructions on performing these measurements, download the full Ultrameter III 9P Operation Manual.

# Myron L<sup>®</sup> Company – Ultrameter III<sup>™</sup> 9P Quick Start Guide

Handheld Conductivity, Resistivity, TDS, pH, ORP, Hardness, Alkalinity, LSI, Free Chlorine Equivalent (FC<sup>E™</sup>), and Temperature Meter

## NOTES:

- When finished making Conductivity, Resistivity, TDS, Alkalinity or Hardness measurements, rinse the cell cup with clean water (preferably DI, RO, or distilled).
- When finished measuring pH, ORP or FC<sup>E</sup>, rinse sensor well with clean water (preferably DI, RO, or Distilled), refill it with Myron L<sup>®</sup> pH/ORP Sensor Storage Solution then reinstall the protective cap.

## II. Solution Mode Selection

- Press **COND**, **RES** or **TDS**, to select which parameter is having its solution type changed.

- Press and hold **CAL** about 3 seconds or until "SEL" appears on the display.
- Use the **MS** or **MR** key to select type of solution desired. The possible solution types are KCl, NaCl or 442 Natural Water<sup>™</sup> Standard.
- Press **CAL** to accept new solution type.

NOTE: The solution mode selection determines the salt solution characteristic used to model temperature compensation for conductivity, resistivity and TDS.

## CALIBRATION SOLUTIONS

Mode	Standard Solution or Buffer
Conductivity KCl	KCl: 7000 µS
TDS 442 <sup>™</sup>	442 <sup>™</sup> : 3000 PPM
pH	4.0, 7.0 and 10.0 buffer
Alkalinity	100 ppm Alkalinity Standard Solution
Hardness	200 ppm Hardness Standard Solution
FC <sup>E™</sup> ORP calibration is electronic and based on pH Cal Results	
Resistivity is the reciprocal of Conductivity. To calibrate resistivity, calibrate conductivity for the solution type you wish to measure	

## I. CONDUCTIVITY OR TDS CALIBRATION

- Rinse cell cup 3 times with proper standard solution.
- Refill cell cup with fresh, standard solution.
- Press **COND** or **TDS**, then press **CAL**, "CAL" will appear.
- Press **MS** or **MR** until display agrees with standard solution.
- Press **CAL** to accept value.

NOTE: A deviation of more than 10% from standard solution value will produce a "FAC" on the display. Press **CAL** to accept factory calibration, or clean the cell and recalibrate.

## II. ALKALINITY and HARDNESS CALIBRATION

- For complete instructions on performing these calibrations, download the full Ultrameter III 9P Operation Manual.

## I. BATTERY REPLACEMENT (LOBATT)

- Clean and dry the instrument THOROUGHLY.  
**WARNING: ONLY** open the 9P in a clean and dry environment!
- Remove the four (4) bottom screws.
- Open the instrument CAREFULLY.
- Carefully detach the battery from the circuit board.
- Replace with a new 9-volt alkaline battery.
- Replace bottom, ensuring the sealing gasket is installed in the groove of the top half of case.
- Reinstall the 4 screws, tightening them evenly and securely.

## II. CAUTIONS

- Solutions in excess of 71°C/160°F should not be placed in the cell cup area; this may cause damage.
- The pH/ORP sensor may fracture if the 9P temperature is allowed to go below 0°C/32°F.
- The Conductivity cell cup should be kept clean. Flushing with clean water following use will prevent buildup on electrodes. If very dirty samples (particularly scaling types) are allowed to dry in the cell cup, a film will form reducing accuracy.

## CALIBRATION

### III. pH CALIBRATION

- Rinse sensor well and cell cup 3 times with 7.0 buffer solution.
- Refill sensor well and cell cup with 7.0 buffer solution.
- Press **pH**, then **CAL**, "CAL", "7" and "BUFFER" will appear on the display.
- Press **MS** or **MR** until display agrees with buffer value.
- Press **CAL** once to accept the value.
- Rinse 3 times with pH 4.0 or pH 10.0 buffer solution.
- Refill and repeat steps 4 & 5.
- Rinse 3 times with opposite buffer solution, refill and repeat steps 4 & 5 for a 3-point calibration, or press **CAL** to exit.
- When calibration is complete, rinse the sensor well then fill it with Myron L<sup>®</sup> pH/ORP Sensor Storage Solution and reinstall the protective cap.

### IV. ORP/ FC<sup>E</sup> CALIBRATION

- ORP electrodes rarely give false readings without problems in the reference electrode.
- For this reason, and because calibration solutions for ORP are highly reactive and potentially hazardous, your Ultrameter III has an electronic ORP calibration.
- This causes the zero point on the reference electrode to be set whenever pH 7 calibration is done.

## MAINTENANCE

- The pH/ORP sensor in your 9P should not be allowed to dry out.
- Whenever the pH/ORP sensor is not in use make sure it is filled with Myron L<sup>®</sup> Company pH/ORP Sensor Storage Solution and that the protective cap is in place.

## III. CLEANING SENSORS

### A. Conductivity, TDS, Resistivity, Alkalinity, Hardness, and LSI

- When there are visible films of oil, dirt, or scale in the cell cup or on the electrodes, or if readings are not as expected, clean cell using isopropyl alcohol or a foaming non-abrasive household cleaner.
- Rinse out the cleaner, and your 9P is ready for accurate calibration then measurements.

- B. pH/ORP:** If the pH/ORP sensor dries out or becomes dirty, it may be cleaned and/or reconditioned. For instructions on performing these operations, download the full 9P Operation Manual from the Myron L<sup>®</sup> Company website.

### IV. pH/ORP Sensor Replacement

Order model RPR. Be sure to include the model and serial number of your instrument to ensure receipt of the proper type. **NOTE:** Complete installation instructions are provided with each replacement sensor.

## SPECIFICATIONS

Spec	CONDUCTIVITY	TDS	RESISTIVITY	pH	ORP	ALKALINITY	HARDNESS	LSI	FC <sup>E™</sup>	TEMP
Ranges	0 - 9999 µS/cm 10 - 200 mS/cm <i>In 5 autoranges</i>	0 - 9999 ppm 10 - 200 ppt <i>In 5 autoranges</i>	10 kΩ - 30 MΩ	0-14 pH	±999 mV	10-800 ppm	0-1710 ppm (0-100 grains)	-10 to +10	0.00 - 9.99 ppm ORP = 350mV - 725 mV, <9.9 pH ORP = 725 mV - 825 mV, <8.9 pH	0°C - 71°C 32°F - 160°F
Resolution	0.01 (<100 µS) 0.1 (<1000 µS) 1 (<10 mS) 0.01 (<100 mS) 0.1 (<200 mS)	0.01 (<100 ppm) 0.1 (<1000 ppm) 1 (<10 ppt) 0.01 (<100 ppt) 0.1 (<200 ppt)	0.01 (<100 kΩ) 0.1 (<1000 kΩ) 0.1 (>1 MΩ)	0.01 pH	1 mV	0.1 ppm	0.1 (<1000 ppm) 1 (<1710 ppm) 0.1 (<100 grains)	0.1	0.01 ppm	0.1 °C / °F
Accuracy	±1% of reading	±1% of reading	±1% of reading	±0.01 pH	±1 mV				±0.3 ppm <1.0 ppm ±0.2 ppm ≥1.0 ppm	±0.1 °C
COND/TDS Ratios	Programmed: KCl, NaCl or 442 <sup>™</sup> , Adjustable 0.20 -07.99									
Temperature Compensation	Auto: 0-71°C, 32-160°F, Adjustable from 0 - 9.99% / °C			Auto: 0-71°C, 32-160°F						

