

AQUASWITCH I & AQUASWITCH II

Operation Manual

24 August 05

INSTALLATION • OPERATION • MAINTENANCE

Resistivity Model: ASIIR

Conductivity/TDS Model: ASIIC

ACCURACY • RELIABILITY • SIMPLICITY

**MYRON L
COMPANY**
Water Quality Instrumentation
Accuracy • Reliability • Simplicity

AQUASWITCH I & II™

QUICK REFERENCE GUIDE!

If you read nothing else in this manual please read this Quick Reference Guide.

PLEASE READ and COMPREHEND ALL WARNINGS, CAUTIONS and ADVISEMENTS CONTAINED WITHIN THIS MANUAL.

Failure to comply is beyond the responsibility of the Myron L Company.

WARNING: ALL MONITOR/CONTROLLERS ARE FACTORY SET TO OPERATE ON 115 VAC. BEFORE APPLYING POWER ENSURE THE INPUT POWER "115/230 VAC" SELECTION IS CORRECT FOR YOUR REQUIREMENTS. FAILURE TO DO SO IS BEYOND THE RESPONSIBILITY OF THE MYRON L COMPANY. See section II.E.2. and figure II.E.1.

WARNING: ENSURE POWER IS OFF WHILE INSTALLING ELECTRICAL EQUIPMENT. IF MONITOR/ CONTROLLER IS INSTALLED, ENSURE THE POWER IS OFF BEFORE SERVICING. FAILURE TO DO SO COULD CAUSE DAMAGE TO THE INSTRUMENT, AND COULD BE HARMFUL OR FATAL TO PERSONNEL. ONLY QUALIFIED PERSONNEL SHOULD INSTALL OR SERVICE ELECTRICAL EQUIPMENT.

WARNING: THE DISPLAY WILL BE IRREPARABLY DAMAGED IF THE DISPLAY HARNESS IS INSTALLED UPSIDE-DOWN OR MISALIGNED. THE HARNESS MUST BE INSTALLED AS SHOWN IN FIGURE II.E.5.

CAUTIONS:

Before installation, ensure you have the correct model (with options), AND it is ranged for your application. See sections I.A., I.B. & I.G.

Do you have the correct sensor? See section I.E. Mounting requirements. What is needed? See section II.B.

The following will give the installer and user a quick overview. See the sections listed for details.

REMOVING FRONT PANEL

NOTE: When opening instrument, remove front cover with care; a ribbon cable connects the front panel and main board.

1. Ensure power is **OFF**.
2. Remove the two (2) screws on the front panel.
3. Carefully wiggle the front panel and pull gently toward you. Do not pull more than about 8 inches/20CM or you could damage the wiring harness.

REASSEMBLY

1. Carefully reinstall the front panel, bottom first. Ensure no wires have been pinched between enclosure and front panel.
2. Reinstall the two (2) screws and tighten.
3. To operate, turn power **ON**.

INTRODUCTION - Section I.

This section covers the specifications of your new AQUASWITCH including sensor information.

INSTALLATION - Section II.

This section covers how to install your new AQUASWITCH; mechanically and electrically.

OPTIONS & ACCESSORIES - Section III.

This section covers the specifications, installation, set up, and operation of each option.

QUICK LOCATOR

-4A/4AO MODULE (4-20mA), see section III.A.

-PA/PAO (Piezo Alarm), see section III.B.

-TP/TPO (Temperature Module, see section III.C.

RA (Remote Alarm), see section III.D.

OPERATING PROCEDURES - Section IV.

This section covers a brief description of the models and their features; how they work, and how to set them up for your particular use.

QUICK SET POINT CONVERSION (SPC) /

REVERSING SET POINT - See Section IV.B.1.

Resistivity AQUASWITCH II's are configured to trigger the alarm relay as the resistivity reading decreases.

Conductivity/TDS AQUASWITCH II's are configured to trigger the alarm relay as the conductivity/TDS reading increases.

To reverse:

1. Locate the jumper block for the alarm to be configured. See figure V.A.1.
2. Remove and rotate the jumpers 1/4 turn and reinstall them on their posts.

QUICK CHECK-OUT PROCEDURE -

See Section IV.C.

It is assumed that the AQUASWITCH power is ON, that it is connected to an appropriate Sensor, and that the Sensor is immersed in water within the range that the AQUASWITCH II will be required to control; and the front panel is removed.

1. Make a note of the reading on the display.
2. While pressing the Calibration/Full Scale Test Switch (FS SW), verify that the front panel display is indicating a full scale reading. If not, see Calibration, section V.C.
3. Press and hold the "SET POINT" switch on the front panel. Using a tweaker or a small screwdriver, adjust the Set Point trimmer adjustment screw on the circuit board to sweep the display from zero to full scale. (A digital display may be blank at the full scale end. This is normal.) Listen for the alarm relay to click on and off as the alarm set point moves past the water reading.
4. Adjust the alarm to the desired set point value. Release the "SET POINT" switch.

Continued

QUICK SET POINT ADJUSTMENT -

See Section IV.B.2.

The set point setting is based upon the user's particular water purity specifications or requirements.

1. While pressing the "SET POINT" switch, turn the Set Point #1 adjustment screw (see figure V.A.1) until the desired set point value is indicated on the display.

HYSTERESIS (DEAD BAND) ADJUSTMENT -

See Section IV.B.3.

PRIMARY COMPONENT IDENTIFICATION -

Section V.A.

Review the figure below to familiarize yourself with the different circuit boards and component locations. The diagram has the second alarm/control module option installed.

"PURGE CYCLE" CALIBRATION PROCEDURE

Section V.B.

"ALARM RESET" MODE CHANGE PROCEDURE

Section V.C.

QUICK CALIBRATION - Section V.D.

WARNING: When performing calibration procedures, the technician must take extreme care to avoid contacting the circuitry other than the CALibration control. Failure to do so could result in damage to the equipment, property and/or personal injury.

The following assumes the front panel has been removed and the power is ON.

ELECTRONIC CALIBRATION (CIRCUIT ONLY) -

See Section V.D.1.

Full Scale Calibration V.D.1.a.

1. Press and hold the Full Scale Test switch. The display should indicate Full Scale for the particular range selected, i.e. 0-20 M should indicate 20. If not, set to Full Scale with the CALibration control.
2. Turn power OFF.
3. Re-install front panel as described in "REASSEMBLY".
4. To operate, turn power ON.

10VDC Calibration - See Section V.D.1.b.

USING STANDARD SOLUTIONS - See Section V.D.2.

The BEST method of verifying and recalibrating your conductivity/TDS AQUASWITCH II is with NIST traceable Standard Solution (available from the Myron L Company). Because it includes the sensor, the entire system is recalibrated. **NOTE:** Since standard solution calibrations are NOT practicable with resistivity models, another means of verification or calibration of resistivity models is to use the transfer standard method, using a hand-held or portable instrument capable of resistivity measurements, such as the Myron L Ultrameter™. See section V.C.4 for description.

SENSOR SUBSTITUTE CALIBRATION -

See Section V.D.3.

TRANSFER STANDARD METHOD - See Section V.D.4.

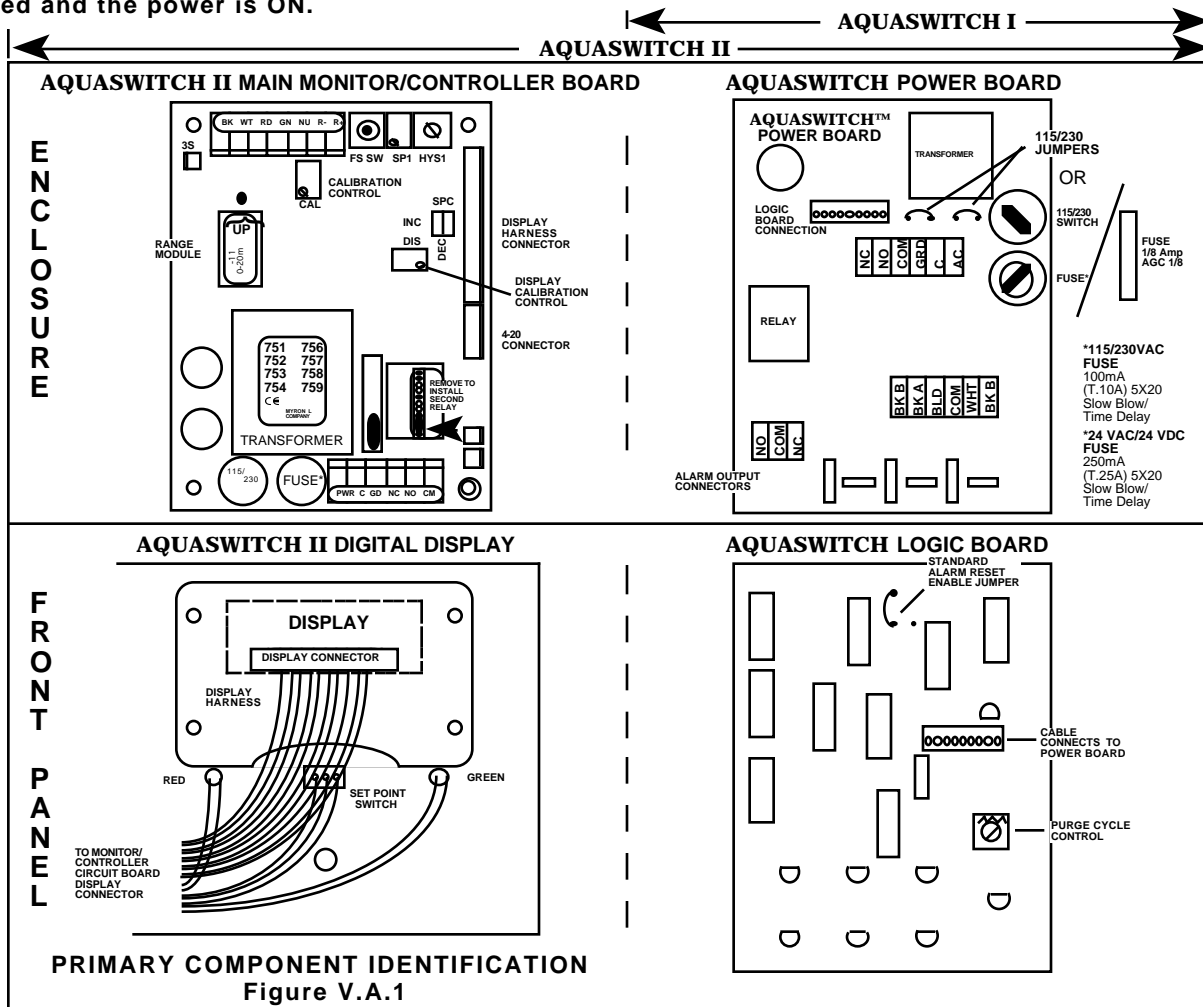



AQUASWITCH I™



AQUASWITCH II™

Model ASIIR-11

(A Digital Resistivity AQUASWITCH II,
with a Range of 0-20 M)

TABLE OF CONTENTS

SECTION	PAGE
AQUASWITCH™ ILLUSTRATIONS (ASI & ASIIR-11)	1
I. INTRODUCTION	4
A. SCOPE	4
1. Functional Descriptions	4
2. Applications	4
B. SPECIFICATIONS	4
C. OPTIONAL FEATURES	5
D. ACCESSORIES	5
E. SENSORS	6
1. Conductivity/TDS	6
2. Resistivity	6
3. Sensor Specifications	6
F. ORDER INFORMATION	6
1. How to order AQUASWITCH	6
2. How to order Sensors	6
G. RANGE SELECTION GUIDE	8
II. INSTALLATION	9
A. GENERAL	9
B. MECHANICAL INSTALLATION	9
1. Surface Mounting with SMP (surface mounting plate) Assembly	9
2. Surface Mounting without SMP Assembly	9
3. Panel Mounting	10
4. Surface and Panel Mounting Diagrams	10
C. SOLENOID VALVE INSTALLATION	11
D. SENSOR INSERTION / DIP MOUNT ASSEMBLIES (ASII)	11
1. Insertion Mode Assembly	11
2. Alternate Dip Sensor Assembly	11
E. ELECTRICAL INSTALLATION	11
1. AQUASWITCH I Main AC Power Installation	12
2. AQUASWITCH II Main AC Power Installation	12
3. 115/230 VAC Conversion	13
4. Connecting the Sensor Cable (ASII)	13
a. USP 25 Modification (No Temperature Compensation)	14
5. Solid State Output Connection (ASII)	15
a. Piezo Electric Alarm Installation (option)	15
b. Remote Alarm Connection (RA option)	15
c. Connect to your own alarm or indicator	15
6. Pilot Valve Solenoid Connection	16
7. Alarm/Control Relay Connection	17
8. Connecting Display Harness to Display (ASII)	17
F. 0-10 VDC OUTPUT (ASII)	18
1. Connection	18
2. Voltage Divider	18
G. RE-RANGE YOUR AQUASWITCH II (Range Module Installation)	19
1. Description	19
2. Installation	19
III. OPTIONS & ACCESSORIES INSTALLATION (ASII)	20
A. 4A/4AO MODULE (4-20mA OPTION)	20
1. Description	20
2. Installation	20
3. Recalibration	21
4. Converting a Current to a Voltage	23
B. PA PIEZO ALARM	24
1. Description	24
2. Installation	25
C. TP/TPO MODULE (TEMPERATURE OPTION)	26
1. Description	26
2. Installation	26

TABLE OF CONTENTS Continued

SECTION	PAGE
3.	Recalibration 28
a.	TPC "Calibration" Module Procedure 28
b.	Precision Resistor Calibration Procedure 28
c.	System Calibration 29
D.	RA REMOTE ALARM 30
1.	Description 30
2.	Installation 30
IV.	OPERATING PROCEDURES 32
A.	FRONT PANEL INDICATORS & CONTROLS 32
1.	AQUASWITCH I 32
2.	AQUASWITCH II 32
3.	Optional Front Panel Items 32
B.	SETUP PROCEDURES 33
1.	Set Point Conversion (SPC) or Reversing Set Point 33
3.	Set Point Adjustment 33
3.	Hysteresis (Dead Band) Adjustment 33
C.	OPERATIONAL CHECKOUT PROCEDURES 33
1.	AQUASWITCH I 33
2.	AQUASWITCH II 34
V.	COMPONENT IDENTIFICATION, CALIBRATION AND PREVENTIVE CARE 35
A.	PRIMARY COMPONENT IDENTIFICATION 35
B.	PURGE CYCLE CALIBRATION PROCEDURE 36
C.	ALARM RESET MODE CHANGE PROCEDURE 36
D.	CALIBRATION PROCEDURES - MAIN CIRCUIT BOARD (ASII) 37
1.	Electronic Calibration (Circuit Only) 37
2.	Calibration Using Standard Solution 37
3.	Sensor Substitute Calibration 38
4.	Transfer Standard Method 38
E.	PREVENTIVE CARE 39
F.	ALTERNATIVE VALVING CONFIGURATIONS & OPERATION for CONTINUOUS PROCESS WATER 39
VI.	OPTIONS & ACCESSORIES 40
A.	OPTIONS ORDERED WITH AQUASWITCH 40
B.	OPTIONS & ACCESSORIES ORDERED SEPARATELY 40
C.	CONDUCTIVITY/TDS STANDARD SOLUTIONS 41
VII.	REPLACEMENT PARTS 42
VIII.	WARRANTY 43
IX.	GLOSSARY 44
X.	NOTES 45
XI.	ADDENDUM 46
A.	CONDUCTIVITY, TDS, RESISTIVITY & TEMPERATURE RELATIONSHIPS 46

I. INTRODUCTION

Thank you for selecting one of the Myron L Company's newest AQUASWITCH Monitor/controllers. The new AQUASWITCH™ series is based on input from 'you' - our customers, time proven designs, and many years of instrumentation experience.

Since 1957, the Myron L Company has been providing customers with quality products at an affordable price by designing and producing products that are Accurate, Reliable, Simple to use. Quality you have come to rely and depend on.

As you read through this operation manual you will see the new AQUASWITCH is truly designed to be user friendly with simple to install options, and easy re-rangeability as conditions or applications change. This manual is actually more complex than the AQUASWITCH, but must be to address all the variables.

A. SCOPE

This operation manual provides the user with the necessary information to install, operate and maintain the Myron L Company's latest AQUASWITCH Resistivity & Conductivity/TDS Controllers.

Section I. Descriptions, Applications, Specifications.

Section II. Installation; mounting, wiring and set up.

Section III. Options and Accessory installation procedures.

Section IV. Operating procedures.

Section V. Identifies their primary components and provides the user with easy-to-use calibration and preventive care procedures.

Section VI. Options & Accessories List.

Section VII. Replacement Components.

Section VIII. Warranty information.

Section IX. Glossary, definitions.

Section X. Notes.

Section XI. Addendum.

1. FUNCTIONAL DESCRIPTIONS

Both models have water & corrosion resistant IP64/NEMA 3 housings suitable for panel, bench or surface mounting.

The AQUASWITCH I is packaged within a compact 6.0" x 4.8" (152mm x 122mm) housing. The AQUASWITCH II is packaged within a 6.0" x 10.8" (152mm x 274mm) housing.

The AQUASWITCH I does not monitor water quality itself, but should be used with any reliable resistivity or conductivity/TDS controller such as the Myron L Company's 750 Series II Resistivity or Conductivity/TDS Monitor/controllers.

The AQUASWITCH II is an integrated unit requiring no other Monitor/controller.

AQUASWITCH I:

Provides automatic switching from exhausted to fresh DI banks; push-button override for immediate bank change-over; adjustable purge timer for "FAILSAFE" operation; front panel LED displays provide continual status of both DI banks; and an alarm is automatically activated as each bank is depleted.

AQUASWITCH II:

AQUASWITCH II combines the operating features of the AQUASWITCH I with the additional features of a Monitor/controller. These include: a 3 1/2 digit Liquid Crystal Display and a front panel accessible "SET POINT CHECK" switch. (Set point setting is internal to discourage unauthorized adjustments).

NOTE: All specifications for the AQUASWITCH I also apply to AQUASWITCH II unless otherwise indicated. Bright green/red LEDs indicate HIGH/LOW set point readings. All AQUASWITCH II's feature a heavy-duty 10 amp output relay, operating on either increasing or decreasing readings. May use the optional 4-20mA output for PLC or SCADA operations.

2. APPLICATIONS

Conductivity/TDS

Reverse Osmosis

Process Control

Seawater Desalinization

Food Processing

Plating

Power Plants

Laboratories

Printing

Are just a few of the applications

Resistivity

Deionization (DI) and Distillation Ultrapure Water Treatment Systems

Electronics

Pharmaceutical

Laboratories

Food Processing

Plating

Power Plants

Are just a few of the applications

B. SPECIFICATIONS

1. GENERAL ASI & ASII

INPUT POWER:

115/230 VAC ±15%, 50/60 Hz (User selectable)
overvoltage category II

100 mA Maximum Current

Double Insulated (with circuit board ground for OEM operation)

Fuse - 100mA Slow Blow (T.10A) for both 115 & 230 VAC (V~)
User replaceable

Humidity - 20-90% non-condensing

Max. Altitude -

40,000 ft/12,000 meters non-operating

10,000 ft/3000 meters operating

Pollution degree 2

24 VAC or 24 VDC Option available on Special Order

Overvoltage category II (24 VAC)

250 mA Maximum Current

Double Insulated (with circuit board ground for OEM operation)

Fuse - 250mA Slow Blow (T.25A) User replaceable

AMBIENT TEMPERATURE RANGE

32°F (0°C) to 131°F (55°C)

OUTPUT POWER:

24 VAC (Standard if ordered with Myron L valves)

115 VAC (Standard if ordered without Myron L valves)

230 VAC (Optional)

MAXIMUM LOAD PER VALVE OUTPUT:

200 milliamps;

(5 watts for a 24 V valve)

(25 watts for a 115 V valve)

(50 watts for a 230 V valve)

AMBIENT TEMPERATURE RANGE:
32°F (0°C) to 140°F (60°C)

HOUSING CONSTRUCTION

Fully gasketed heavy-duty ABS for splashproof and corrosion resistance.
Rated IP64/NEMA 3
Double Insulated (with circuit board ground for OEM operation)

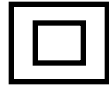

DOUBLE INSULATED

DIMENSIONS

AQUASWITCH I:
6" (152mm) H x 4.8" (122mm) W x 3.8" (97mm) D
AQUASWITCH II:
6" (152mm) H x 10.8" (274mm) W x 3.9" (99mm) D

SHIPPING WEIGHT

AQUASWITCH I: 3 lbs. (1.36 kg.)
AQUASWITCH II: 5 lbs. (2.27 kg.)

ALARM RELAY CONTACT RATING:

SPDT 10 amp @ 250 VAC (Non-Inductive), 30 VDC

2. AQUASWITCH II

RANGES

7 Resistivity ranges from 0-200K to 0-20M
14 Conductivity/TDS ranges from
0-1µS/µM/ppm to 0-100µS/µM/ppm
Refer to Range Selection Guide on Page 8.

DISPLAY

1/2" (13mm) 3 1/2 digit LCD. (Optional 3 1/2 digit back lit LCD)

ACCURACY

± 1 % of Full Scale

SENSITIVITY

0.05% of span

STABILITY

0.05% of span

REPEATABILITY

0.1% of span

CALIBRATION CHECK

Built in full scale value

RECORDER OUTPUT

0-10 VDC @ 5mA max. (linear); standard on all models

OUTPUT IMPEDANCE

100 ±5%

SENSOR INPUT

Resistivity — 1 CS10 sensor
Conductivity/TDS — 1 CS51LC sensor up to 0-10
1 CS51 sensor above 0-10

CONTROL FUNCTION

Models ASIIC & ASIIR:
Single set point alarm/control continuously adjustable

0-100% of span

Hysteresis

Adjustable from 0.3-3% of full scale

Indicators

"HIGH" (red) and "LOW" (green) set point LEDs - reversible.

Relay Contact Rating

SPDT 10 amp @ 250 VAC, 30 VDC. Relay operates increasing or decreasing reading (user selectable).

Solid State Output

24VDC unregulated, 30mA Maximum.

Powers optional PA - Piezo Electric Alarm, Remote Alarm - RA™, or indicator of your own choosing.

C. OPTIONAL FEATURES

- 4A 4-20 mA Isolated output (ASII)
- PA 70 db Piezo Electric Alarm (ASII)
- PAT Piezo Alarm & Timer Module (ASII)
- 35BL 3 1/2 digit backlit LCD (ASII)
- PC 115 VAC Powercord (8 ft. with USA plug and strain relief) - NOT for use with 230 VAC.
- 24VA 24 VAC isolated power supply (special order)
- 24VD 24 VDC isolated power supply (special order)
- PTS Panel mounted Full Scale Test Switch ((ASII - special order)

D. ACCESSORIES (ordered separately)

- 4AO 4-20 mA Isolated output
- PAO 70 db Piezo Electric Alarm ONLY (ASII)
- 35BLO 3 1/2 digit backlit LCD (ASII)
- PCO 115 VAC Powercord (8 ft. with USA plug and strain relief) - NOT for use with 230VAC.
- SMP50 Surface Mounting Plate
- RA Remote Alarm - RA™ (ASII)
- VR Powersupply, 24VAC, 20VA (115VAC, indoor use)
- CS-11 20 Megohm sensor substitute (NIST Traceable)
- CS-14 2 Megohm sensor substitute (NIST Traceable)
- CS-17 200 Kiloohm sensor substitute (NIST Traceable)

E. SENSORS

All sensors feature integral thermistor style temperature sensors to ensure accurate, rapid and reliable automatic temperature compensation.

1. CONDUCTIVITY/TDS

AQUASWITCH II Conductivity/TDS Monitor/controllers use the CS51LC or CS51 Series sensor depending on range. The 1.0 cell constant CS51 model is recommended for ranges of 0-10 through 100 $\mu\text{S/ppm}$. Its compact size allows mounting in a standard 3/4" tee. The sturdy polypropylene bushing is modular for easy, inexpensive replacement. Other models available by special order.

CS51LC sensor has a cell constant of 0.1 and is used for conductivity/TDS values of 0-1 to 0-5 $\mu\text{S/ppm}$.

2. RESISTIVITY

AQUASWITCH II Resistivity Monitor/controllers use the CS10 sensor. It has a cell constant of 0.05 and is used for ultra pure water applications. Other models available by special order.

Special order High Temperature, High Pressure sensors; and Low Cost, Low Temperature, Low Pressure sensors are available.

For detailed descriptions of these and other sensors, see Sensor Selection Guide and specific sensor data sheets available from your local distributor, the Myron L Company, or on line at www.myronl.com.

3. SENSOR SPECIFICATIONS

STANDARD MODELS — 316 Stainless Steel		CONSTANT
CS10:	For ALL Resistivity ranges	0.05
CS51 LC:	For ranges 0-5 $\mu\text{S/ppm}$ & below	0.1
CS51:	For ranges between 0-10 & 0- 100 $\mu\text{S/ppm}$	1.0

See Range Selection Guide, Page 8.

SPECIAL ORDER MODELS — 316 Stainless Steel

CS40	Resistivity/Conductivity/TDS Valve Insertable 100PSI@150°C (1.0, 0.1 & 0.05)
CS40HT	Above High Temperature Model 250PSI@205°C
CS41	Cond/TDS High Temperature Model 100PSI@150°C
CS41HT	Cond/TDS High Temperature Model 250PSI@205°C
CS50	Conductivity/TDS 100PSI@95°C (1.0 & 0.1)
CSA	Low Cost Conductivity/TDS - NO Temperature Compensation 75PSI@60°C (1.0)
CSATC	Low Cost Conductivity/TDS - with Temperature Compensation 75PSI@60°C (1.0)

4. SENSOR OPTIONS

-T	Titanium - in place of Stainless Steel
-25	25' Shielded Cable
-100	100' Shielded Cable
-PV	1/2" PVDF fitting for CS10 & CS51 ONLY {replaces polypropylene}
-HPSS	1/2" 316 STAINLESS STEEL fitting for CS10 & CS51 ONLY (replaces polypropylene).
-STF	Sanitec Fitting for CS10, CS51 & CS51LC. 1/2" thru 4". State size, i.e. STF-1/2.

Special Order Options

-WTV	Wet-Tap Valve for CS40 (0.1 & 1.0 only)
-JB	Junction Box - Class I, Group D, Div. S, Explosion proof, Weather proof, Aluminum. For

CS40 ONLY.

TEMPERATURE COMPENSATION

Automatic to 25°C, between 32-212°F (0-100°C)
except high temperature models - up to 205°C.

PRESSURE/TEMPERATURE LIMITS

CS10 & CS51 - 100 psi (689.6 kPa) at 212°F (100°C)
For higher limits, see specifications below.

BUSHING

CS51 (LC): Modular Polypropylene threaded 3/4" NPT
CS10: Modular Polypropylene threaded 3/4" NPT

CABLE

Shielded; 10' (3 meters) standard.
25' (7 meters), and
100' (30 meters) lengths also available.

DIMENSIONS

CS51(LC): Metal portion 1.2" (30mm) L; 0.5" (13mm) DIA
CS10: Metal portion 1.2" (30mm) L; 0.5" (13mm) DIA

For other models see sensor selection & specific data sheets for details.

F. ORDERING INFORMATION

1. HOW TO ORDER AN AQUASWITCH

Choose either an AQUASWITCH I or an AQUASWITCH II.

AQUASWITCH I order as - ASI

No sensor required, skip to How to Order Valve(s), if required.

AQUASWITCH II

EXAMPLE: order as -

MODEL	RANGE*	OPTIONS
ASIIR	— 11	— 4A - PA

Written as — ASIIR-11-4A-PA

This is a Resistivity AQUASWITCH II Monitor/controller with a 0-20M range, a 4-20mA output and a Piezo electric Alarm.

*RANGE SUFFIXES:

See RANGE SELECTION GUIDE, Page 8.

NOTE: AQUASWITCH II model number does not include sensor. Please specify sensor required when ordering. See How to Order Sensor.

See How to Order Valve(s).

2. HOW TO ORDER A SENSOR

Add option to model number as in examples below.

EXAMPLE:

MODEL	OPTIONS
CS10	— TP-100

Written as — CS10-TP-100

The above is a model CS10 sensor made with Titanium, and a 100 foot cable.

EXAMPLE:

MODEL	OPTIONS	CS40HT
01-T-WTV		—

Written as — CS40-01-T-WTV

The above is a Special Order High Temperature sensor with a cell constant of 0.1, made of Titanium, and a Wet-Tap Valve.

Additional Ordering Information

NOTE: 24 VAC power is required for use with 24 VAC valves. A 115 VAC to 24 VAC step-down transformer accessory is available.

Order Model VR

EXAMPLE of a COMPLETE SYSTEM (ASI):

- 1) ASI AQUASWITCH I
- 1) VR Power supply 115 VAC to 24VAC
- 4) XXXXX 24 VAC Valves (user supplied)

EXAMPLE of a COMPLETE SYSTEM (ASII):

- 1) ASIIR-11-PA AQUASWITCH II, 0-20M range with optional audible alarm
- 1) CS10-T Titanium Sensor
- 1) VR Power supply 115 VAC to 24VAC
- 4) XXXXX 24 VAC Valves (user supplied)

G. AQUASWITCH II RANGE SELECTION GUIDE CONDUCTIVITY/TDS & RESISTIVITY

Add Range NUMBER below to instrument model number, i.e. ASIIR -"11" = 0-20M Controller .

RANGE	ASIIC	ASIIR
	CONDUCTIVITY/TDS Dash #	RESISTIVITY Dash #
Resistivity		
0-20 M		-11
0-10 M		-12
0-5 M		-13
0-2 M		-14
0-1 M		-15
0-500 K		-16
0-200 K		-17
Conductivity		
0-1 μ S*	-101	
0-1 ppm*	-102	
0-2 μ S*	-103	
0-2 ppm*	-104	
0-5 μ S*	-105	
0-5 ppm*	-106	
0-10 μ S	-107	
0-10 ppm	-108	
0-20 μ S	-109	
0-20 ppm	-110	
0-50 μ S	-111	
0-50 ppm	-112	
0-100 μ S	-113	
0-100 ppm	-114	

*CS51LC conductivity sensor (0.1 constant) required for these ranges.

Conductivity/TDS AQUASWITCH II Controllers require a sensor with a cell constant of 1.0. The Model CS51 is the most commonly selected sensor due to its ease of use and low cost.

Resistivity AQUASWITCH II Controllers require a sensor with a cell constant of 0.05. The Model CS10 is the most common selected due to its ease of use and low cost.

NOTE: UNLESS ppm/NaCl is specified with order, TDS/ppm type conductivity instruments will be calibrated to the Myron L "442™" Natural Water standard. For NaCl ppm/ppt add the letter "N" after the number, i.e. -114N.

II. INSTALLATION

A. GENERAL

This section provides the recommended procedures for properly installing the AQUASWITCH I Controller, or AQUASWITCH II Monitor/controller, Valve(s), and Sensor. Figure II.A.1 gives an overview of the entire system. Alternate configurations on page 39.

rotated or mounted upside down so that the cutouts are on the opposite side.

4. AQUASWITCH II

For best results, position your Monitor/controller and sensor as close as possible to the point(s) being controlled. The AQUASWITCH II Resistivity & Conductivity/TDS Monitor/controllers are not designed to operate with a sensor cable length that exceeds 100' (30 meters).

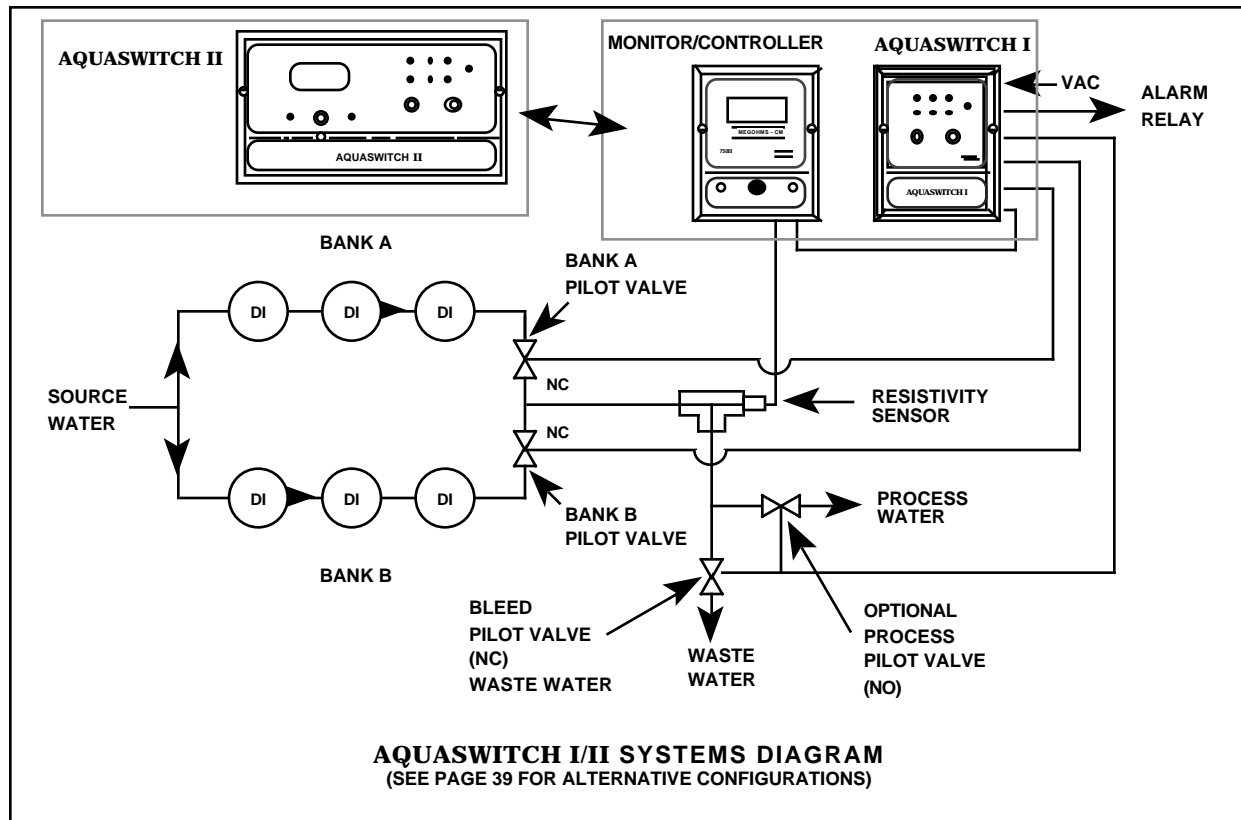

Figure II.A.1.



CAUTION - READ FOLLOWING CAREFULLY

WARNING: THE MYRON L COMPANY RECOMMENDS THAT ALL MOUNTING AND ELECTRICAL INSTALLATIONS BE PERFORMED BY QUALIFIED PERSONNEL ONLY. FAILURE TO DO SO COULD CAUSE DAMAGE TO INSTRUMENT, AND COULD BE HARMFUL OR FATAL TO PERSONNEL.

B. MECHANICAL INSTALLATION

All AQUASWITCH electronics are packaged inside drip/weather-proof housings. The physical dimensions of the housing is suitable for panel, bench or surface mounting. There are four basic guidelines to consider when selecting a mounting location:

1. Select a site that limits the AQUASWITCH's exposure to excessive moisture and corrosive fumes.
2. If at all possible, mount the AQUASWITCH at eye level for viewing convenience.
3. **AQUASWITCH I**
If needed, the AQUASWITCH I enclosure may be

1. SURFACE MOUNTING WITH SMP

NOTE: A Surface Mounting Plate (AQUASWITCH I - #SMP50) or (AQUASWITCH II - #SMP60) may be required when access to the back side of the mounting site is impractical or if the AQUASWITCH must be mounted on a solid wall. Both SMP's come with the proper hardware to mount the AQUASWITCH to the SMP, however, the installer must provide the four (4) additional screws/bolts to mount the SMP to the wall or fixture. Their type and size is to be determined by the user.

1. Select your mounting location. Mark and drill the four (4) required mounting holes. For hole locations, use the SMP as a template.
2. Drill the corner holes in the SMP according to the size of the screws or bolts selected.
3. Attach and securely fasten the SMP to the Monitor using the 1/4" X 20 X 3/8" screws provided.
4. Mount the SMP to the prepared site using the selected screws or bolts.

2. SURFACE MOUNTING WITHOUT SMP

NOTE: Surface mounting will require two (2) 1/4" X 20 screws of a length equal to the thickness of the mounting site plus 3/8"

1. Select mounting site location. Mark and drill the required mounting holes. For hole drilling locations, see figure II.B.1.
2. Insert the 1/4" X 20 screws into the holes from the side opposite the mounting site.
3. Hold the Monitor in place while starting and tightening the mounting screws.

3. PANEL MOUNTING

A panel mounting fastening kit is provided with all AQUASWITCH's. Panel mounting will require the use of the fastening kit's two (2) 4-40 mounting screws/nuts or two (2) #4 x 1/2" sheet metal screws. See figures II.B.1 & II.B.2. for panel cutout dimensions.

1. Select your mounting location. Mark the appropriate panel cutout and complete the necessary panel cut.

AQUASWITCH I

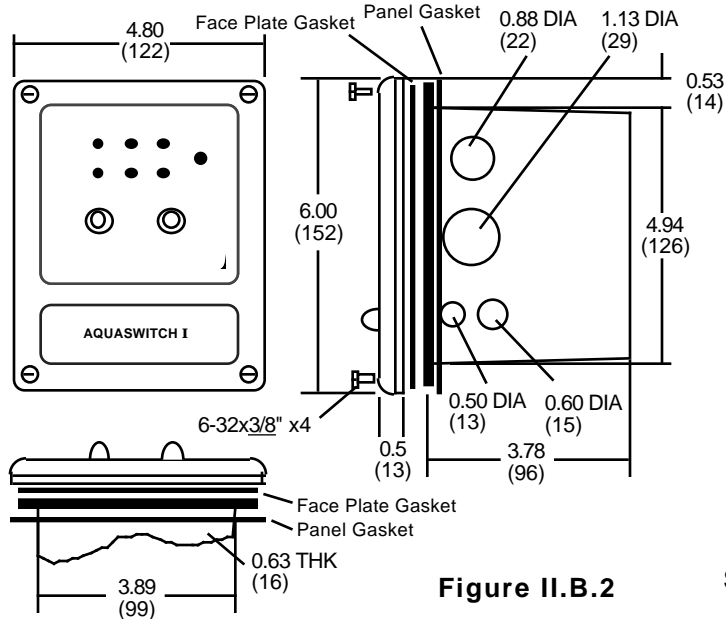
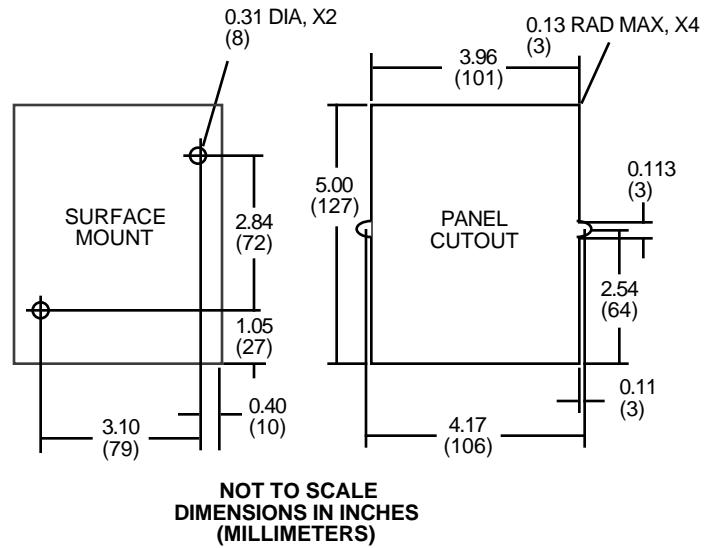

Figure II.B.2



NOT TO SCALE
DIMENSIONS IN INCHES
(MILLIMETERS)
SURFACE AND PANEL MOUNTING DIAGRAMS

AQUASWITCH II

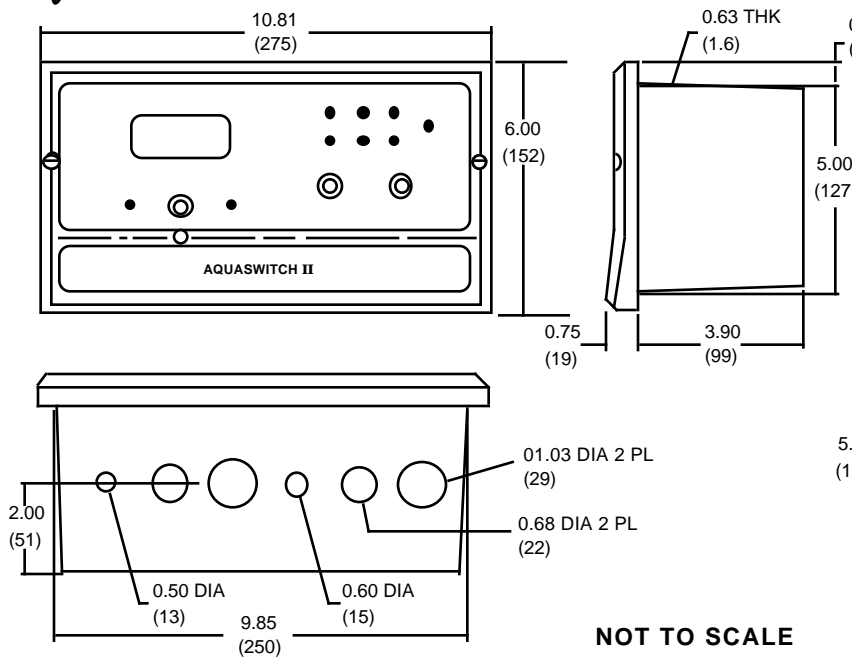
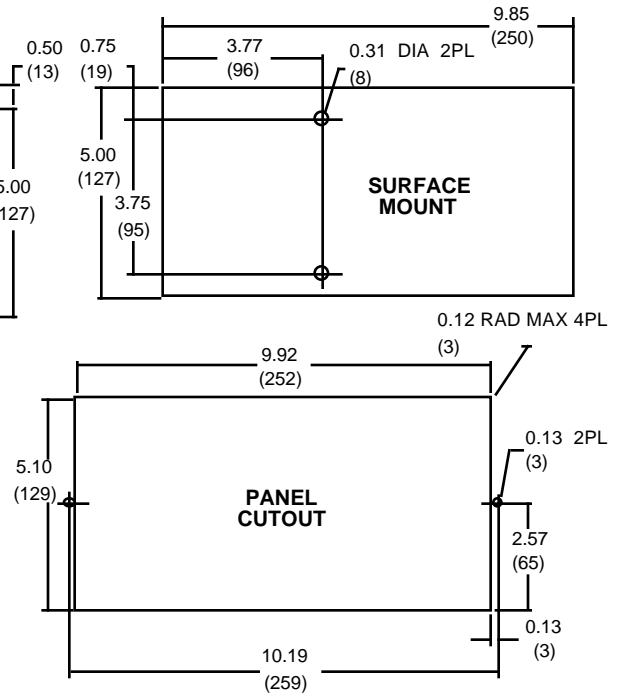
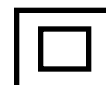

Figure II.B.3



NOT TO SCALE
DIMENSIONS IN
INCHES
(MILLIMETERS)



DOUBLE INSULATED

SURFACE AND PANEL MOUNTING DIAGRAMS

- Carefully unfasten and separate the AQUASWITCH's front panel from its enclosure.
- Disconnect all panel cable(s)/wires from the AQUASWITCH's Control board.
- Slide the enclosure through the panel cutout until its flange contacts the panel.
- Insert mounting screws through the flange mounting holes and tightly secure.
- Reconnect all panel cable(s)/wires and reinstall the front panel.

C. SOLENOID VALVE INSTALLATION

There are many types of solenoid valves. The user must decide which type is best suited for the specific application. The following is an example installation of one type of valve,

- Insert the pilot valve unit so that the systems' INFLOW source and OUTFLOW process piping connecting ends are inserted into the valve as shown in figure II.C.1.
- Repeat step until all appropriate pilot valve units have been installed.

NOTE: The number of pilot valves used will be based upon the user's desired application.

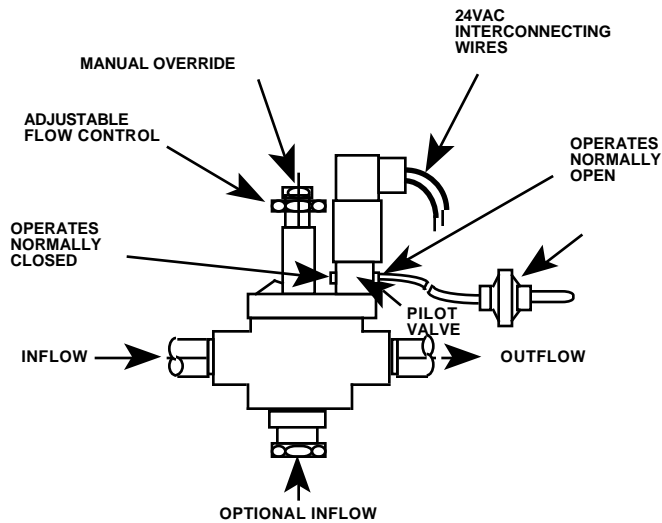

SOLENOID VALVE MOUNTING DIAGRAM

D. SENSOR INSERTION/IMMERSION MOUNTING

The SENSOR's mounting orientation must provide a continuous and adequate circulation flow to prevent the trapping of air bubbles within the Sensor's electrode area (CS10 shown in figures II.D.1 & II.D.2). Failure to do so will result in conditions that will prevent the Sensor from functioning properly.

1. INSERTION MODE (in-line installation)

Use approved sealant, i.e. Teflon tape as required.

- Verify that the Sensor's Fitting assembly is properly assembled as shown in figure II.D.1.
- Insert the Sensor Fitting assembly into the "T" fitting with electrode aligned as shown in figure II.D.1. and tightly

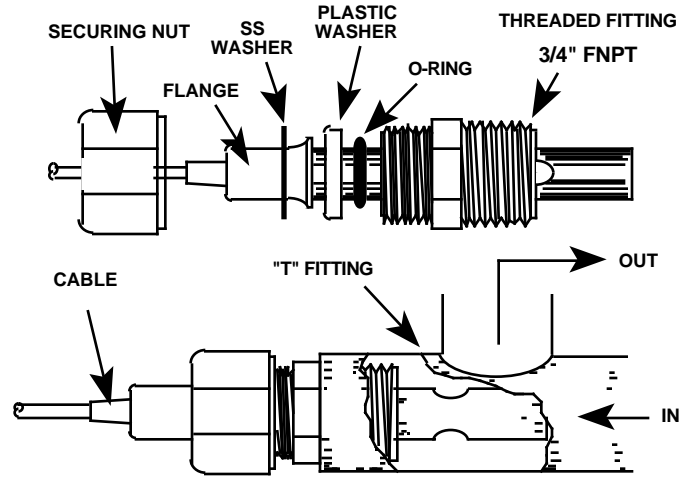

INSERTION MODE ASSEMBLY

Figure II.D.1.

2. IMMERSION OR DIP SENSOR ASSEMBLY

Use approved sealant, i.e. Teflon tape as required.

- Verify that the Sensor's Fitting assembly is properly assembled as shown in figure II.D.2.
- Insert and pull the Sensor's cable through the extension tube and then tightly attach extension tube to Sensor assembly as shown in figure II.D.2.

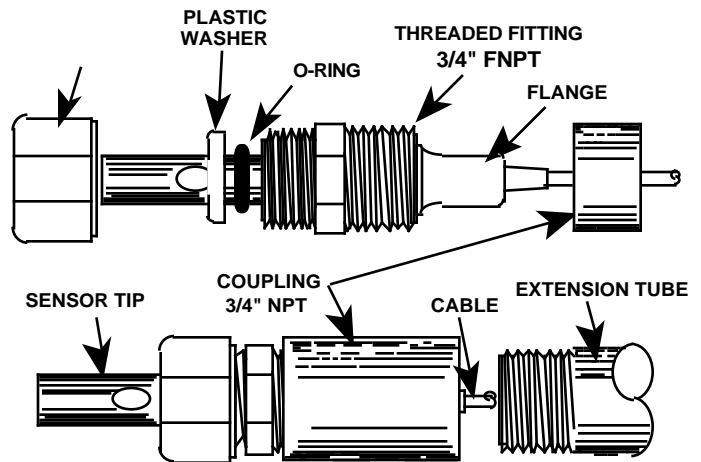

IMMERSION OR DIP SENSOR ASSEMBLY

Figure II.D.2

E. ELECTRICAL INSTALLATION

The AQUASWITCH I and AQUASWITCH II require the user to follow separate electrical installation procedures. In addition, based on the user's solenoid voltage specifications, the user will be required to connect Solenoid Power.

NOTE: All cable watertight restraints are user supplied.



WARNING !

A device to disconnect the AQUASWITCH from the power supply is required. It is recommended that this switch or circuit breaker be labeled as the disconnection device for the AQUASWITCH.

1. AQUASWITCH I MAIN INPUT POWER

WARNING: All AQUASWITCH I's are factory set for 115 VAC. Before starting, ensure the input power "115/230" selection is correct for your requirements. Failure to do so is beyond the responsibility of the Myron L Company. See section II.E.3. and figure II.E.1 and II.E.2.

NOTE: Some models may have either a 24 VAC or a 24 VDC input power requirement - check labels carefully.

1. Verify that the main AC power source is turned "OFF" or disconnected.
2. Using a standard slot screwdriver remove the two (2) screws on the front panel.
3. Carefully wiggle the front panel to loosen the gasket and pull gently toward you. Do not pull more than about 8 inches/20CM or you could damage the wiring harness.
4. Turn the front panel around so that the back side is facing you and set aside for now.
5. Using the enclosure cutouts, install the proper wire and watertight cable restraint (not provided) to comply with local electrical codes.
6. Neatly connect wires to the AQUASWITCH I's connectors*, as shown in figures II.E.1.

***CAUTION:** The input power connectors require only a small screwdriver, or a pen to push on the release levers†. The release levers may be broken or damaged if not pushed straight toward the circuit board. DO NOT push the release levers sideways.

† Early versions have screw terminals.

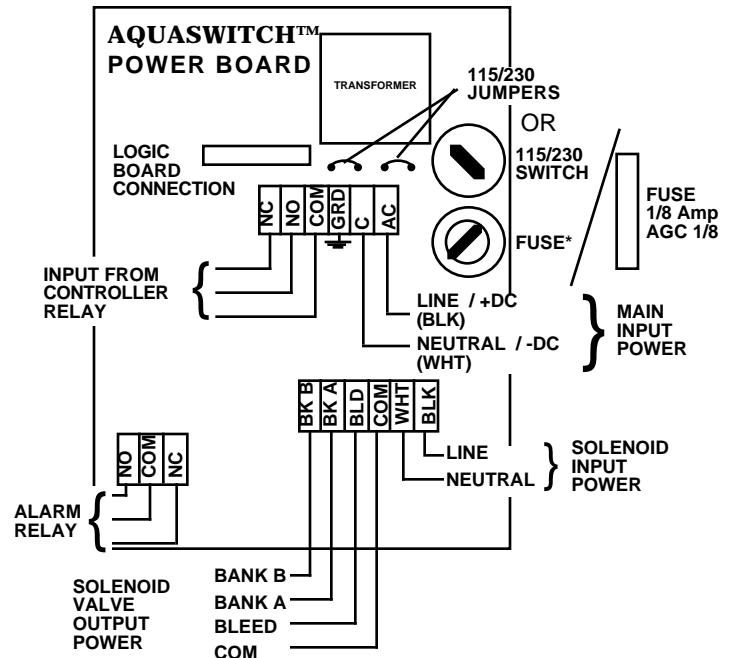

ASI ELECTRICAL CONNECTION DIAGRAM

Figure II.E.1

2. AQUASWITCH II MAIN INPUT POWER

WARNING: All AQUASWITCH II's are factory set for 115 VAC. Before starting, ensure the input power "115/230" selection is correct for your requirements. Failure to do so is beyond the responsibility of the Myron L Company. See section II.E.3. and figure II.E.2.

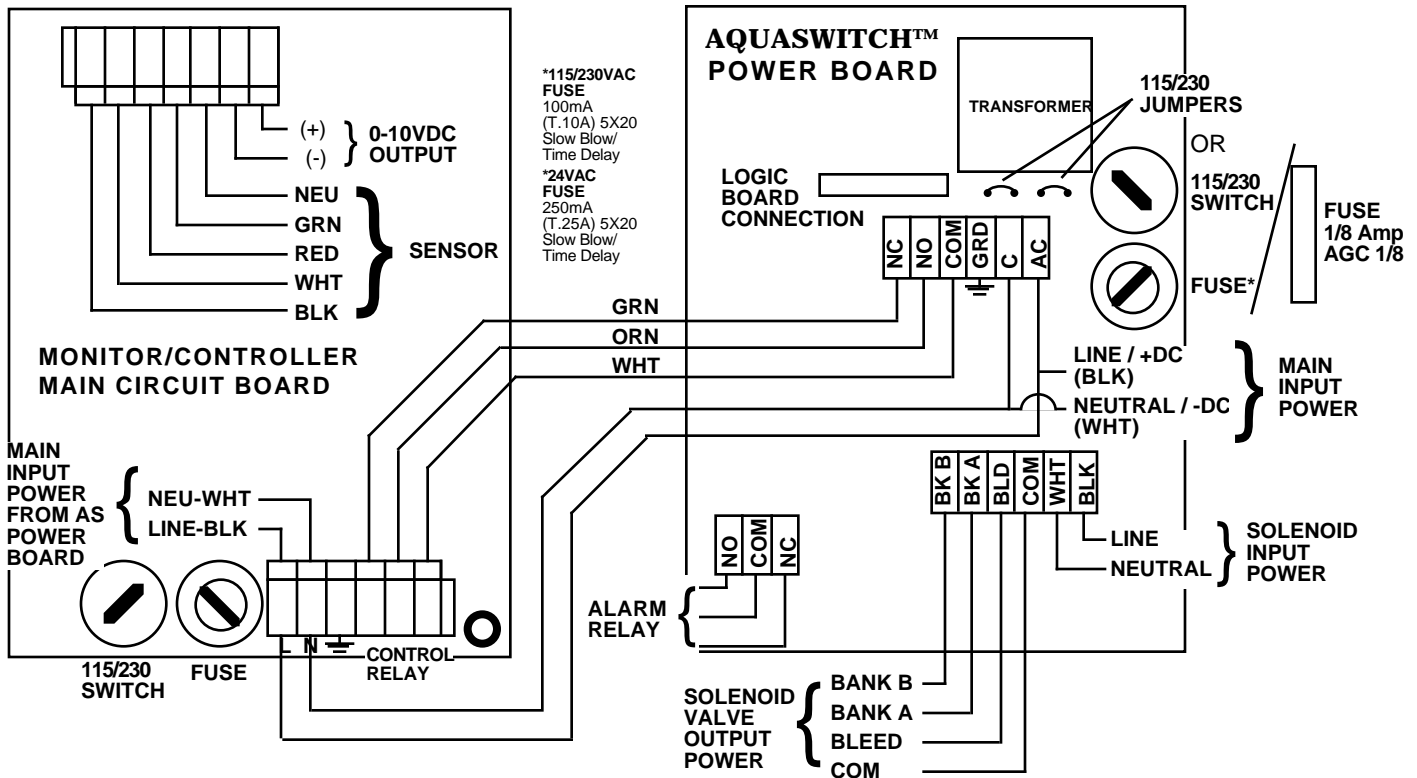

Figure II.E.2

**AQUASWITCH II™
ELECTRICAL CONNECTION DIAGRAM**

The following procedures are to be used to install the AQUASWITCH II to 115 VAC main power source. For the procedures to install the optional 230 VAC main power source, the user must first complete the installation procedures in Section II.E.3. Failure to do so could result in damage to equipment and/or property.

1. Verify that the main power source is turned "OFF" or disconnected.
2. Using a standard slot screwdriver remove the two (2) screws on the front panel.
3. Carefully wiggle the front panel and pull gently toward you. Do not pull more than about 8 inches/20CM or you could damage the wiring harness.
4. Turn the front panel around so that the back side is facing you and set aside for now.
5. Using the enclosure cutouts, install the proper wire and watertight cable restraint (not provided) to comply with local electrical codes.
6. Neatly connect wires to the AQUASWITCH II's connectors*, as shown in figures II.E.2.

***CAUTION:** The input power connectors require only a small screwdriver, or a pen to push on the release levers†. The release levers may be broken or damaged if not pushed straight toward the circuit board. DO NOT push the release levers sideways.
 † Early versions have screw terminals.

3. 115/230 VAC CONVERSION

Before turning power ON to the AQUASWITCH ensure the proper input voltage has been selected. For the AQUASWITCH I, see figures II.E.1 & II.E.3. This is required in TWO locations on the AQUASWITCH II, see figures II.E.2 & II.E.3. Failure to do so will blow the fuse(s). It could, under some conditions, cause injury and damage the instrument voiding the warranty. On the early model AQUASWITCH Power Board the conversion must be accomplished by desoldering and resoldering a buss wire jumper as shown in figure II.E.3, (to desolder and resolder the JUMPERS, the circuit board (CB) must be removed from the enclosure), or may be accomplished as shown in figure II.E.4. Later models have switches, see section II.E.3.b and figure II.E.2.

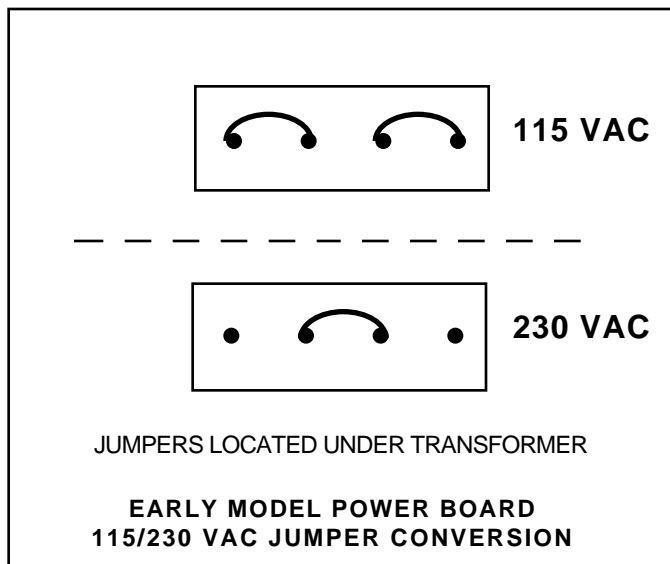

Figure II.E.3

NOTE: Both early and later models function exactly the same.

II.E.3.a. Early Model Power Boards with Buss Wire JUMPERS

This requires extreme care as circuit board may be damaged if improperly attempted.

1. Locate the jumpers below the transformer.
2. Cut jumpers in location as shown in figure II.E.4.
3. Carefully, bend leads toward each other (center) as shown in figure II.E.4.
4. Solder the ends of the leads together.

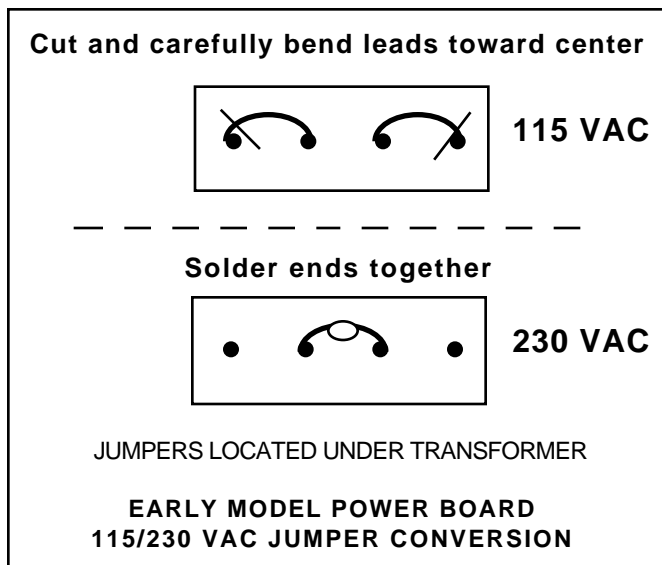

Figure II.E.4

II.E.3.b. Later Model Power Boards with SWITCH

1. Locate switch next to the fuse holder.
2. Using a screwdriver, turn switch to required voltage.

II.E.3.c. AQUASWITCH II Main Control Board

ALL AQUASWITCH II Main Control Boards have a switch. See figure II.E.2.

1. Locate switch next to the fuse holder.
2. Using a screwdriver, turn switch to required voltage.

4. CONNECTING THE SENSOR CABLE

This section provides the procedure to properly wiring the sensor.

1. Place the SENSOR interface cable and user supplied watertight cable restraint into the enclosure's appropriate access hole.
2. Install the SENSOR cable wire to comply with local electrical codes.
3. Follow the color code as marked. See figure II.E.2.

***CAUTION:** The sensor connectors require only a small screwdriver or a pen to push on the release levers. The release levers may be broken or damaged if not pushed straight toward the circuit board. DO NOT push the release levers sideways.

a. USP 25 MODIFICATION

(No Temperature Compensation)

This simple modification will allow your AQUASWITCH II Monitor/controller to meet the USP 25 requirements by defeating the normal temperature compensation circuit thus giving "uncompensated" readings as required.

Specifications:

As required to meet USP25.

Installation

Briefly -

For Resistivity models, two resistors are installed in place of the sensor "temperature" sensing leads.
For Conductivity/TDS models, a resistor is installed in place of the sensor "temperature" sensing leads.
The extra sensor leads are either cut off or the ends are wrapped in tape to prevent shorting.



CAUTION - READ FOLLOWING CAREFULLY

WARNING: BEFORE STARTING, IF THE AQUASWITCH II IS INSTALLED, ENSURE THE POWER IS OFF. FAILURE TO DO SO COULD CAUSE DAMAGE TO THE INSTRUMENT, AND COULD BE HARMFUL OR FATAL TO PERSONNEL. ONLY QUALIFIED PERSONNEL SHOULD INSTALL OR SERVICE ELECTRICAL EQUIPMENT.

Requirements:

For Resistivity; one 100k 1% resistor, and one 5.49K 1% resistor, user supplied or may be ordered from the Myron L Company.

For Conductivity/TDS; one 10k 1% resistor, user supplied or may be ordered from the Myron L Company.

NOTE: When opening instrument, remove front cover with care; a ribbon cable connects the front panel and main board. If the front panel has all ready been removed from the enclosure skip to #4.

- Using a standard slot screwdriver remove the two (2) screws on the front panel.
- Carefully wiggle the front panel and pull gently toward you. Do not pull more than about 8 inches/20CM or you could damage the wiring harness.
- Turn the front panel around so that the back side is facing you and set aside.
- For Resistivity Monitor/controllers;
 - If sensor is installed, locate and remove the BLACK (BK), RED (RD), and the NEUTRAL (NU) leads from MAIN Circuit Board, as shown in figure II.E.5.
 - Cut off or tape BLACK (BK), RED (RD), and the NEUTRAL (NU) leads from sensor.
 - Install 100k resistor at BLACK (BK) and GREEN (GN) connector locations, as shown in figure II.E.6.
 - Install 5.49k resistor at RED (RD) and the NEUTRAL (NU) connector locations, as shown in figure II.E.6.

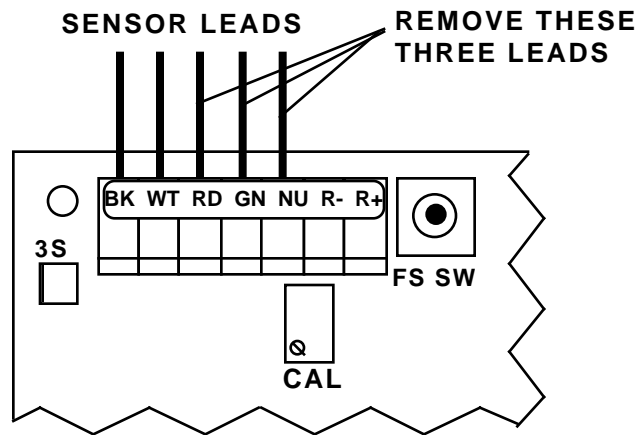

Resistivity Main CB Assembly

Figure II.E.5

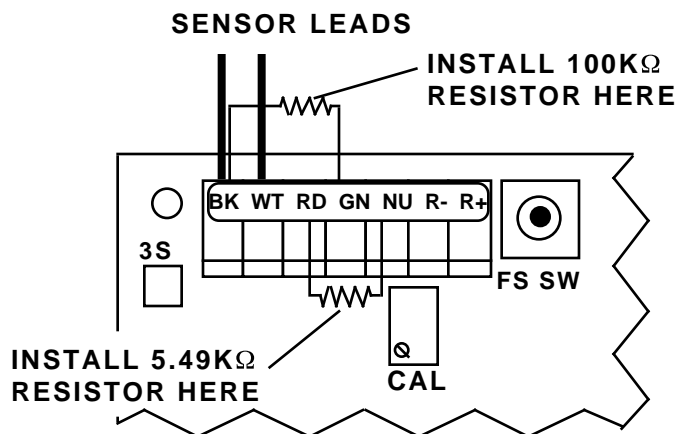

Resistivity Main CB Assembly

Figure II.E.6

For Conductivity/TDS Monitor/controllers;

- If sensor is installed, locate and remove the RED (RD) and the GREEN (GN) leads from MAIN Circuit Board, as shown in figure II.E.7.
 - Cut off or tape RED (RD) and the GREEN (GN) leads from sensor.
 - Install 10k resistor at RED (RD) and the GREEN (GN) connector locations, as shown in figure II.E.8.
- Carefully reinstall the front panel, bottom first. Ensure no wires have been pinched between enclosure and front panel.
 - Reinstall the two (2) screws and tighten.
 - To operate, turn power **ON**.

NOTE: Recalibration will require both the solution and sensor be at 25°C for maximum accuracy.

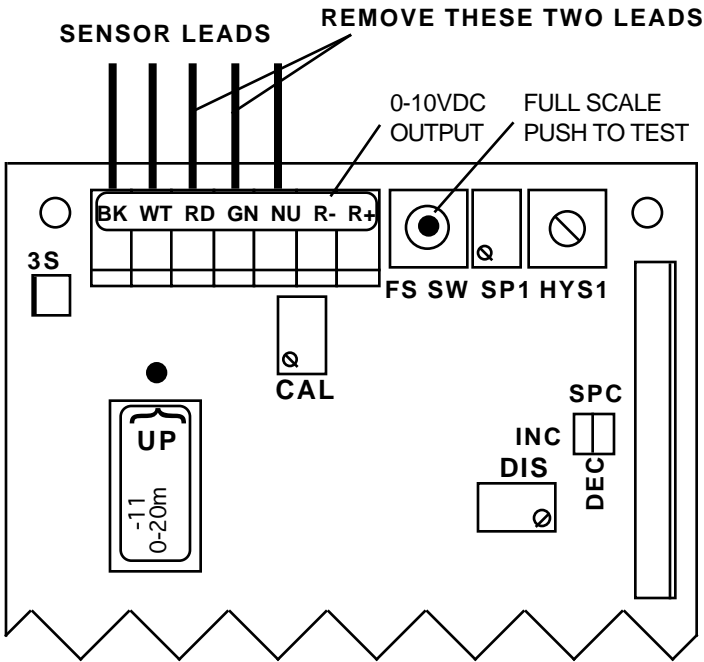

Conductivity/TDS Main CB Assembly

Figure II.E.7

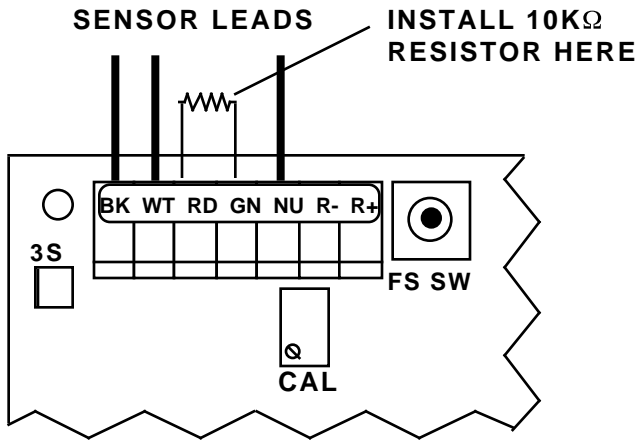

Conductivity/TDS Main CB Assembly

Figure II.E.8

5. SOLID STATE OUTPUT

24 VDC Unregulated 30mA max. The following instructions are assuming the Monitor/controller enclosure is already open.

a. Piezo Electric Alarm - PA/PAO (option)

For additional information, see Piezo Alarm under Options in section III.I.

1. If not already installed, peel tape backing from PIEZO and press into place per figure III.I.3.
2. Attach connector to main control circuit board per figure III.I.4.

NOTE: If remotely mounted; cut wires and splice as necessary, use comparable wire. Piezo requires 1/4" (6.35mm) hole in user panel.

b. Remote Alarm - RA™ (option)

For additional information, see RA Instructions under options in

1. Run user supplied #22, 2 conductor speaker type wire from Monitor/controller to RA location as necessary. Additional wire may be ordered, part #RAW-200, see Options & Accessories.
2. Open the RA by removing the four screws.
3. Locate and remove the 8" 2 conductor wire attached to RA.
4. At the controller, connect the extension wires to the 8" 2 conductor wire with the wire nuts provided — Black to Positive (+) and White to Negative (-). Be sure to first pass the wire through the user supplied waterproof strain relief in the enclosure.
5. Plug the reddish brown female connector into the male connector on the controller CB marked either RA or PA (see inside case label for location). It will only go on the connector one way.
6. At the RA, connect the wires to the connector — Black to Positive (+) and White to Negative (-).
7. To test, simply turn on the controller and adjust controller set point until the alarm/piezo sounds off. If controller is not yet connected to a functioning sensor, on conductivity/TDS controllers it will be necessary to press and hold the Full Scale test switch.

The black button on the front of the RA will mute the piezo alarm for approximately three minutes or until you improve the water quality (readjust controller set point). The piezo alarm will continue to sound off every three minutes until the user has improved the alarm condition inside the controller. If three minutes muting is fine for your application, skip to step 9.

8. If three minutes is too long or too short, adjust time delay control inside RA until desired mute time is achieved adjustable from approximately 6 seconds to 10 minutes).
9. Replace the bottom of the RA, and secure RA to the surface you have selected for its installation.

NOTE: If the RA does not sound off;

1. Check the polarity of the extension wire connections.
2. Be sure the controller is actually switching (relay will click).

c. Connect to your own alarm or indicator

Use the following as guidelines.

Connector is a standard 2 wire Methode* style connector. Connector with 8" wires, part #RAH, is available from the Myron L Company. Ensure your requirements do not exceed the 24 VDC Unregulated 30mA maximum. Ensure the polarity is correct (RED is positive), see figure V.A.1. Attach wires to RA. Attach connector to controller connector (RA) per figure V.A.1.

*Methode is registered trademark of Methode Electronics, Inc.

REASSEMBLY

1. Carefully reinstall the front panel, bottom first. Ensure no wires have been pinched between enclosure and front panel.
2. Reinstall the two (2) screws and tighten.
3. To operate, turn power **ON**.

6. SOLENOID VALVE CONNECTIONS

The solenoid valves require electrical power to operate. This power must be supplied by the user. See figure II.E.10 for the suggested valve wiring. This section provides the procedures for making the appropriate electrical connections.

a. External Power Connection

Valves powered by an external USER supplied source, i.e. 115/230 or 24 VAC.

1. Place the USER supplied power cable and watertight cable restraint into the enclosure's appropriate access hole.
2. Connect the cable wires to the Power Board terminal block as shown in figure II.E.1 or II.E.2.

For 24 VAC applications, the Myron L Company offers a 115 VAC to 24 VAC transformer, Model #VR. Other voltages must be user-supplied.

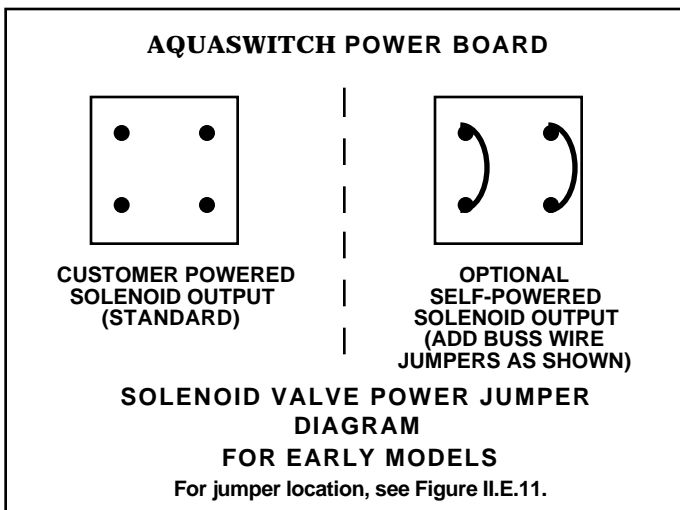

Figure II.E.9

b. Valve Wiring

Suggested method of wiring solenoid valves. See figure II.E.10.

1. Place the Bank A Valve solenoid interface cable and watertight cable restraint into the enclosure's appropriate access hole.
2. Neatly connect the cable wires to Power Board terminal block as shown in figure II.E.1 or II.E.2.
3. Repeat steps 1 and 2 to install the Bank B Valve solenoid interface cable.
4. Repeat steps 1 and 2 to install the Bleed Valve solenoid interface cable.
5. (Optional) Repeat steps 1 and 2 to install the Process valve solenoid interface cable.

REASSEMBLY

1. Carefully reinstall the front panel, bottom first. Ensure no wires have been pinched between enclosure and front panel.
2. Reinstall the two (2) screws and tighten.
3. To operate, turn power **ON**.

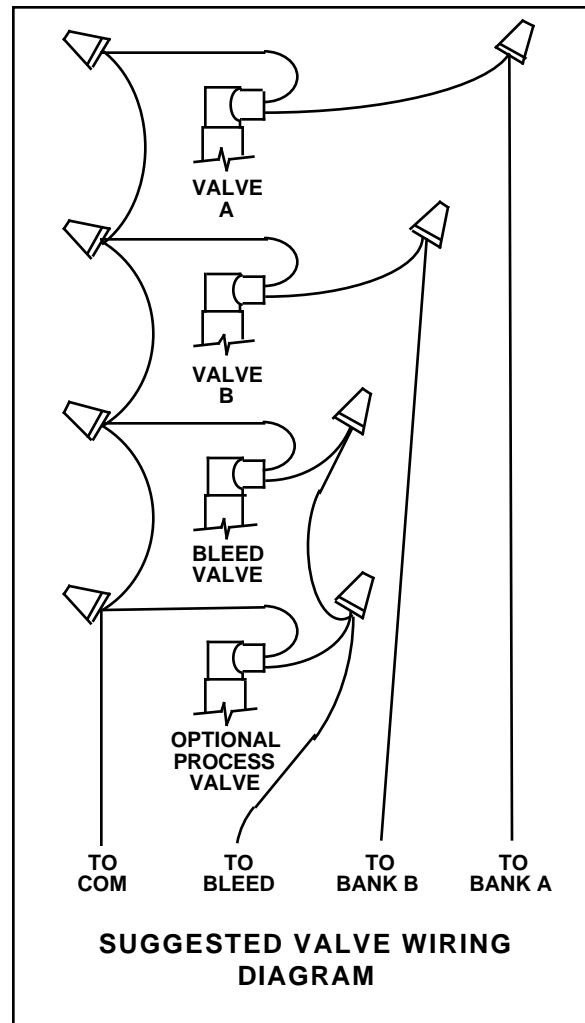
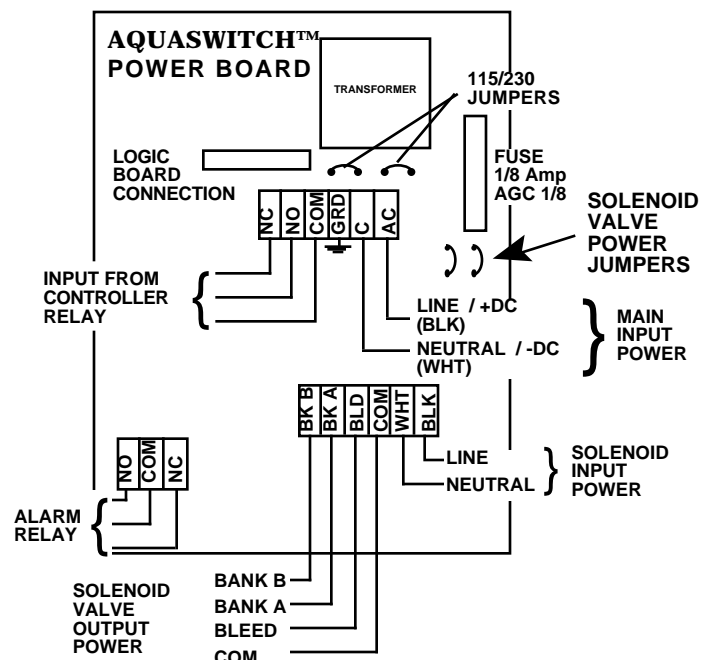

Figure II.E.10



EARLY MODEL AQUASWITCH ELECTRICAL CONNECTION DIAGRAM

Figure II.E.11

7. ALARM/CONTROL RELAY CONNECTIONS

The Myron L Company AQUASWITCH is equipped with a "Dry Contact" relay which is designed to energize/de-energize when the set point is crossed. (See section IV.B.2) for set point adjustment procedure) The relay energizes on increasing or decreasing readings as set by the user, see section IV.B.1.

When energized (above set point), the Common (COM) will disconnect from the Normally Closed (NC) contact and connect to the Normally Open (NO) contact. Devices may be operated using either the Normally Open contact or Normally Closed contact; or both relay contacts may be used to control two devices of the same voltage.

WARNING: CONNECTING BOTH POWER SOURCE LEADS TO THE RELAY TERMINAL BLOCK CONNECTERS WILL DAMAGE THE CIRCUIT BOARD AND MAY CAUSE PERSONAL INJURY.

1. Place the user supplied Alarm relay interface cable and watertight cable restraint into the enclosure's appropriate access hole.
2. Neatly connect the relay interface cable wires to the AQUASWITCH power board terminal block connectors, see figures II.E.1 or II.E.2, and II.E.12 or II.E.13.

CAUTION: The connectors require only a small screwdriver or a pen to push on the release levers. The release levers may be broken or damaged if not pushed straight toward the circuit board. DO NOT push the release levers sideways. Early models have screw terminals.

NOTE: See Section IV.C for the "ALARM RESET" jumper adjustments.

The easiest method of connecting the relay is shown in figures II.E.1 or II.E.2 and II.E.12. These show how the dry contact relay can use incoming power to activate a controlled device (alarm, solenoid valve, etc.) of 10 amps or less.

For 24 VAC applications, the Myron L Company offers a 115 VAC to 24 VAC transformer, Model #VR, see figure II.E.13. Other voltages must be user-supplied.

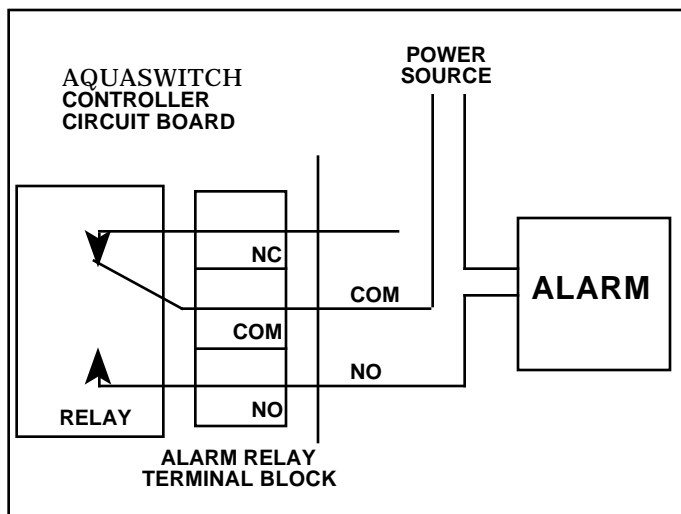

Figure II.E.12

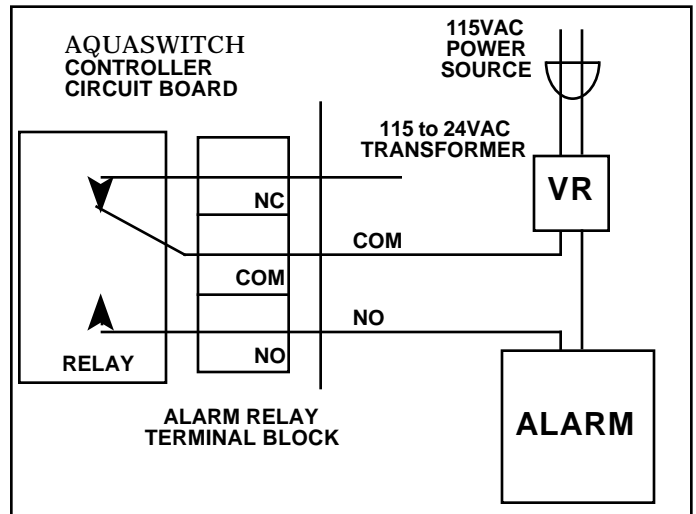

Figure II.E.13

8. CONNECTING DISPLAY HARNESS TO DISPLAY

If the installation required the removal of the display harness from the display, the following procedure will ensure it is reinstalled without damaging the display.

WARNING: THE DISPLAY WILL BE IRREPARABLY DAMAGED IF THE HARNESS IS INSTALLED UPSIDE-DOWN OR MISALIGNED. THE HARNESS MUST BE INSTALLED AS SHOWN IN FIGURE II.E.14.

1. Grasp connector and align wires DOWN on display or with the small edge of the display as shown in figure II.E.14.
2. Press connector onto display pins. Ensure pins are aligned or they may become bent. Wiggle connector slightly "end to end" if necessary.

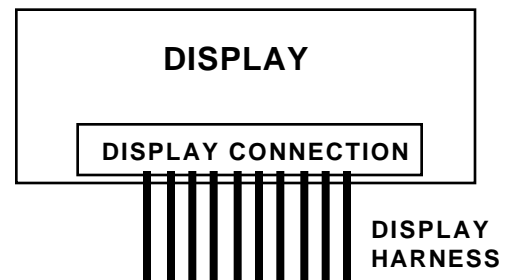

PANEL MOUNTED DISPLAY
REAR VIEW

Figure II.E.14

REASSEMBLY

1. Carefully reinstall the front panel, bottom first. Ensure no wires have been pinched between enclosure and front panel.
2. Reinstall the two (2) screws and tighten.
3. To operate, turn power ON.

F. 0-10VDC RECORDER OUTPUT

The 0-10VDC output is designed to give the user the capability of sending a signal to a remote meter, recorder, PLC or SCADA system.

1. CONNECTION

1. Place the user supplied interface cable and watertight cable restraint into the enclosure's appropriate access hole. Skip for OEM.
2. Connect the Recorder's plus (+) and minus (-) terminal wires to the Recorder output connectors. (See figure II.E.1.)
3. Refer to Section V.D.1.b for the procedures to calibrate the 0-10 VDC voltage output.

2. VOLTAGE DIVIDER

A voltage divider gives the user the ability to scale or tailor the output to a particular need or requirement due to the input of another device, i.e. the output of the Main CB is 0-10V while the input requirement of a particular recording device is 0-5V.

a. INSTALLATION

Briefly—

Two resistors are installed across the 0-10V output. The output is recalibrated to required voltage.

Requirements

Select two (2) resistors as listed;

For 0-5V Output both "A & B" are 2K Resistors.

For 0-1V Output "A" is a 9K resistor and "B" is a 1K resistor.



CAUTION - READ FOLLOWING CAREFULLY

WARNING: BEFORE STARTING, IF THE AQUASWITCH IS INSTALLED, ENSURE THE POWER IS OFF. FAILURE TO DO SO COULD CAUSE DAMAGE TO THE INSTRUMENT, AND COULD BE HARMFUL OR FATAL TO PERSONNEL. ONLY QUALIFIED PERSONNEL SHOULD INSTALL ELECTRICAL EQUIPMENT.

Physical

If the front panel has all ready been removed from the enclosure skip to #3.

1. Using a standard slot screwdriver remove the two (2) screws on the front panel.
2. Carefully wiggle the front panel and pull gently toward you. Do not pull more than about 8 inches/20CM or you could damage the wiring harness.
3. Turn the front panel around so that the back side is facing you and set aside for now.
4. Solder two selected resistors together as shown in figure II.F.1.
5. Attach leads to recording device as shown in figure II.F.1.
6. Attach resistors to 0-10V Output as shown in figure II.F.2.
Ensure resistors and leads DO NOT short to each other or to any part of the CB assembly.
7. Recalibration is required, see Calibration Procedures, section V.D.

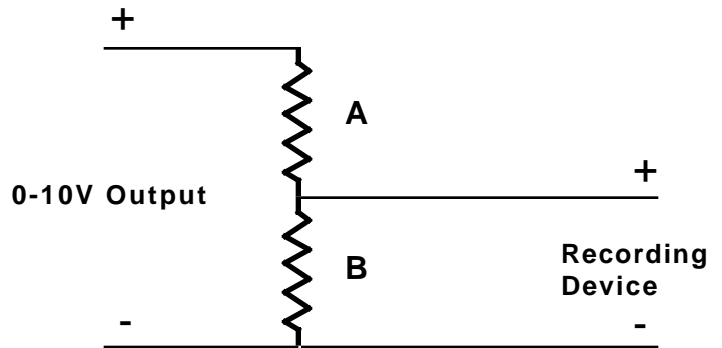
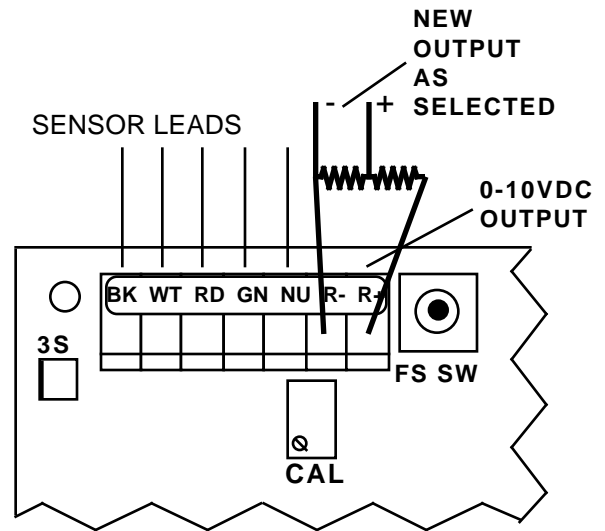

Figure II.F.1



Main CB Assembly

Figure II.F.2

Reassembly

1. Carefully reinstall the front panel, bottom first, ensure no wires have been pinched.
2. Reinstall the two (2) screws and tighten.
3. To operate, turn power **ON**.

G. RE-RANGE YOUR AQUASWITCH II (Range Module Installation)

1. DESCRIPTION

The AQUASWITCH II Monitor/controllers have been designed for easy field re-rangeability. The Range Module consists of a 16 pin Header that plugs into a 16 pin socket.

For available ranges, see Range Selection Guide I.G. When making large range changes in conductivity/TDS, i.e. 1 ppm to 50 ppm, a different sensor may also be required as noted in the Range Selection Guide. Order Range Module by adding the prefix "RM" to the range number as in examples below.

Resistivity Range Modules	—		
RMXX	i.e. = RM11	is a 0-20M	
Conductivity/TDS Range Modules	—		
RMXXX	i.e. = RM111	is a 0-50 μ S	

2. INSTALLATION

Briefly -

The new Range Module simply replaces the Range Module presently installed, see figure II.G.1.

Type label may be required if changing from Microsiemens to PPM.

The Full Scale reading is recalibrated.



CAUTION - READ FOLLOWING CAREFULLY

WARNING: BEFORE STARTING, IF THE AQUASWITCH IS INSTALLED, ENSURE THE POWER IS OFF. FAILURE TO DO SO COULD CAUSE DAMAGE TO THE INSTRUMENT, AND COULD BE HARMFUL OR FATAL TO PERSONNEL. ONLY QUALIFIED PERSONNEL SHOULD INSTALL OR SERVICE ELECTRICAL EQUIPMENT.

Physical

NOTE: When opening instrument, remove front cover with care; a ribbon cable connects the front panel and main board. If the front panel has already been removed from the enclosure skip to #4.

1. Using a standard slot screwdriver remove the two (2) screws on the front panel.
2. Carefully wiggle the front panel and pull gently toward you. Do not pull more than about 8 inches/20CM or you could damage the wiring harness.
3. Turn the front panel around so that the back side is facing you and set aside.
4. Locate and remove existing Range Module from MAIN Circuit Board, as shown in figure II.G.1. It is not easy to remove, it was designed to stay in place under adverse conditions.
5. With the pointer up, carefully align the new Range Module to the socket on the MAIN Circuit Board as shown in figure II.G.1.
6. Press firmly into place.
7. Recalibrate, see CALIBRATION PROCEDURES, section V.D.

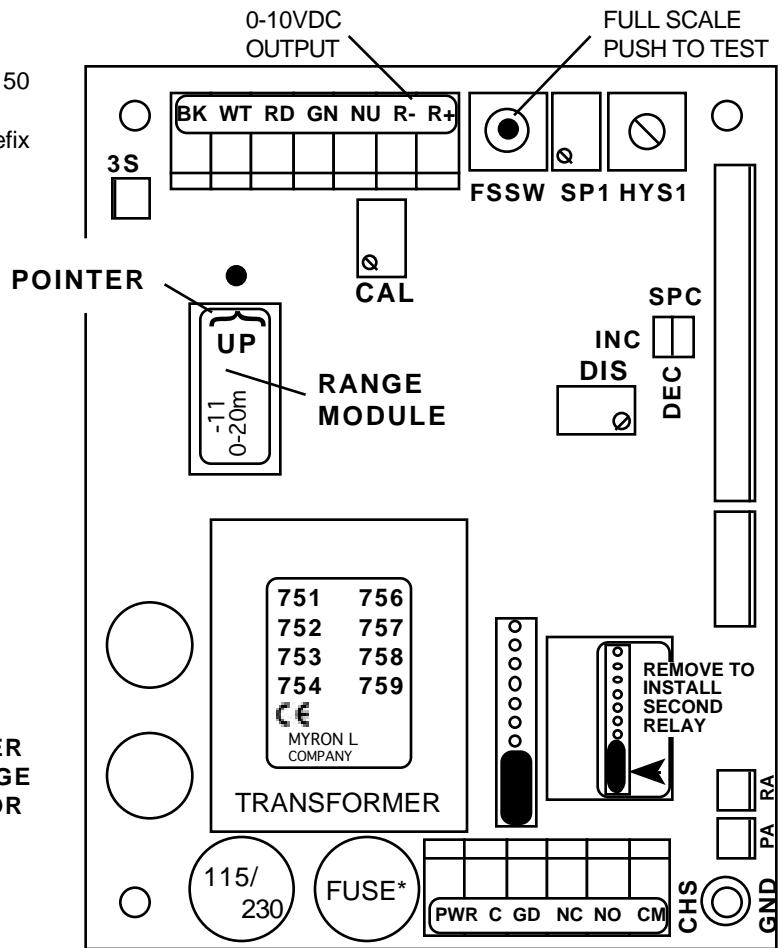

MAIN MONITOR/CONTROLLER CIRCUIT BOARD

Figure II.G.1

III. OPTIONS & ACCESSORIES

A. 4A/4AO MODULE (4-20mA OPTION)

- 4A 4-20mA Self/Remote-powered Isolated output module ordered with Monitor/controller.
- 4AO 4-20mA Self/Remote-powered Isolated output module ordered separately (includes harness).

1. DESCRIPTION

The 4-20mA option gives the AQUASWITCH II Monitor/controller the ability to send a signal very long distances with minimal interferences and signal degradation. The output is an Isolated 4-20mA signal that corresponds to the full scale range of the Monitor/controller into which it is installed. This output is easily configured to be either self-powered or remote-powered as required for your particular application.

NOTE: The maximum impedance of the user's current input instrument should not exceed 600 ohms.

without any degradation of performance.

There are two modes in which current loop transmitters operate; Self-Powered and Remote-Powered.

Self-Powered — the transmitter provides the power to drive the 4 to 20 mA current. See figure III.A.1.

Remote-powered — the receiving instrument provides the power to drive the 4 to 20 mA current. See figure III.A.2.

Specifications

Self-Powered and Remote-Powered

Drive Impedance — 0 to 600

Common Mode Maximum — 120VAC @ 60 Hz

Isolation — 100pf max. to Model 750II circuit common
100pf max. to input power line

Calibration

Two multi-turn pots — Factory Set.

4mA = Zero (0)

20mA = Full Scale

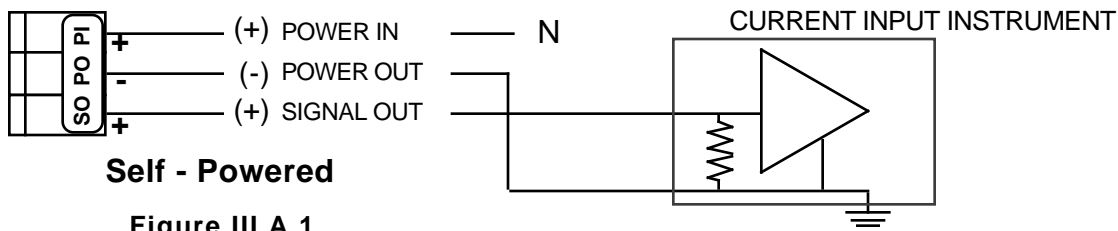

Self - Powered

Figure III.A.1

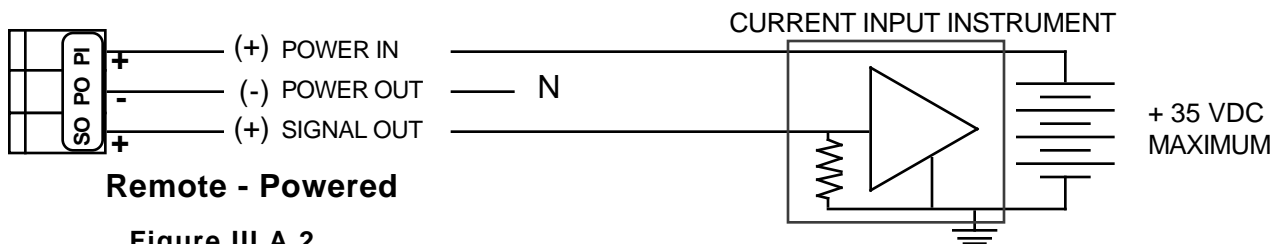

Remote - Powered

Figure III.A.2

4A (4-20mA) Wiring Options

Since the output is an isolated current loop, it is the ideal choice for applications requiring; a control signal to be run very long distances, systems requiring a 4-20mA input or in instances where isolation is necessary.

As the output is isolated, and a current, it is useful for long distance interface, especially where wiring resistances may be high, and/or the ground potentials may differ between the sensor input ground and the current receiving instruments ground.

The 4-20mA output will not be degraded in accuracy even when the ground differences are as much as 120VAC @ 60Hz. Interface wire resistance of 350 Ω will not degrade the accuracy of the output when interfaced to a typical 250 Ω input impedance of a transmitter current input device.

The output is capable of driving a minimum of 600 Ω worst case, therefore, will satisfy virtually all modern interface requirements. Current input devices usually have an input impedance of 250 Ω , however, some older designs can have as high as 500 Ω or as low as 10 Ω . This "-4A" option will drive any impedance from 0 to 600

Calibration is NOT required. However, if you feel you must verify or recalibrate, see Recalibration below.

2. INSTALLATION

Briefly -

The 4-20 Module replaces the plastic display retainer plate attached to the front panel.

The 4-20 Module harness is attached to the main circuit board as marked '4-20'. See figure III.A.4.

The 4-20 output is wired as required - Self-powered or Remote-powered. See figures III.B.1 & III.A.2.



CAUTION - READ FOLLOWING CAREFULLY

WARNING: BEFORE STARTING, IF THE AQUASWITCH IS INSTALLED, ENSURE THE POWER IS OFF. FAILURE TO DO SO COULD CAUSE DAMAGE TO THE INSTRUMENT, AND COULD BE HARMFUL OR FATAL TO PERSONNEL. ONLY QUALIFIED PERSONNEL SHOULD INSTALL ELECTRICAL EQUIPMENT.

Physical

If the front panel has all ready been removed from the enclosure skip to #3.

1. Using a standard slot screwdriver remove the two (2) screws on the front panel.
2. Carefully wiggle the front panel and pull gently toward you. Do not pull more than about 8 inches/20CM or you could damage the wiring harness.
3. Turn the front panel around so that the back side is facing you.

have already connected the other end of the wires as required.

- a. Place the remote interface cable and user supplied watertight cable restraint into the enclosure's appropriate access hole.
 - b. Neatly connect the signal cable wires to the Monitor's appropriate connectors as shown in figure III.A.3.
3. To test, turn power **ON**.
 4. Press the Full Scale Test switch and monitor the output at your remote site, or with a DVM set to DC milliamps.

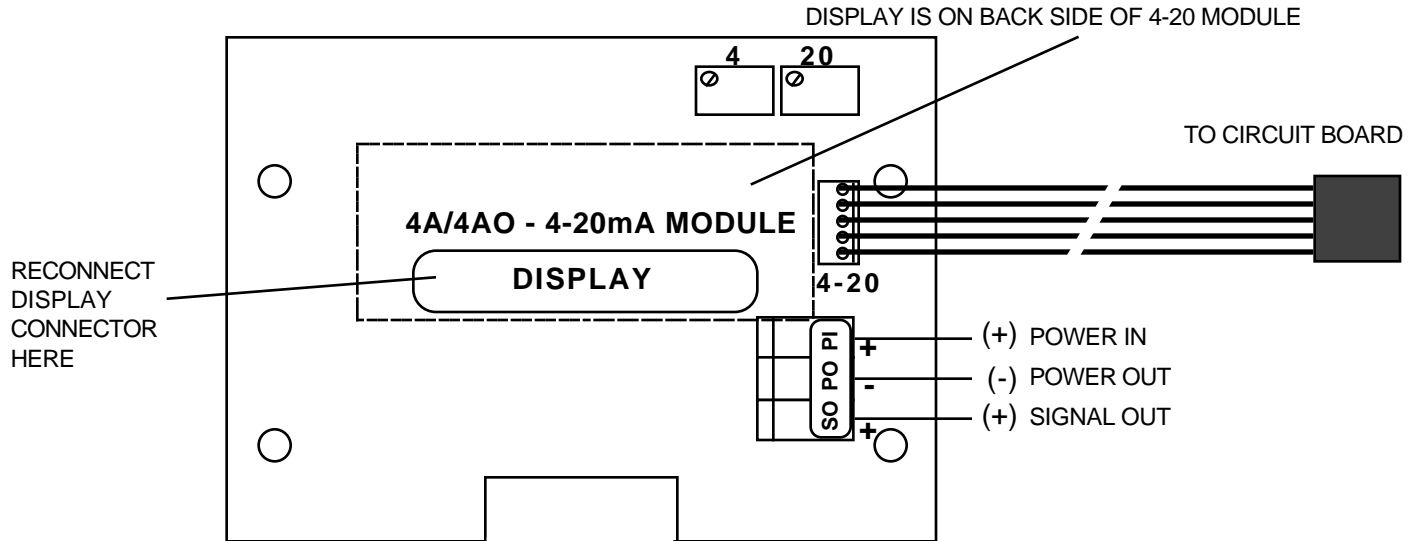

Figure III.A.3.

4. Using a standard slot screwdriver remove the four (4) screws holding the plastic display retainer plate to the front panel. When the screws have been removed, the plastic display retainer plate and the display will be free from the front panel.
5. Set front panel down or carefully allow to hang from the harness. Do not drop as the harness connector will pull out allowing the front panel to fall.
6. While holding the display and the plastic display retainer plate, carefully remove the display harness connector. Do not drop the display. Remove and discard the plastic display retainer plate.
7. While still holding the display in the palm of your hand, set the 4-20 Module over it with the display pins protruding through the center opening as shown in figure III.A.3.
8. Reconnect the harness to the display as shown in figure III.A.3.
9. While holding the front panel, align the display to the opening while at the same time align the 4-20 Module mounting holes to the front panel.
10. Reinstall the four (4) screws and tighten.

Attach the DVM to the output connectors per your requirements, i.e. self-powered or remote-powered, see figures III.A.1. & III.A. 2. If the 4A module is connected properly it will indicate 20mA.

5. Turn power **OFF**.
6. Carefully reinstall the front panel, bottom first, ensure no wires have been pinched between enclosure and front panel.
7. Reinstall the two (2) screws and tighten.
8. To operate, turn power **ON**.

3. RECALIBRATION

The 4-20 Module was calibrated at the factory, however, if you wish to check the calibration the following procedure will help you to accomplish this task. Exercise caution while performing this procedure.

Requirements; a DVM set to DC milliamps, a tweaker or small standard slot screwdriver.

This procedure assumes the front panel is removed.

1. If sensor is connected, disconnect sensor wires from sensor terminal block.
2. Attach the DVM to the output connectors per your requirements, i.e. self-powered or remote-powered, see figure III.A.5.
3. Turn power **ON**, with the front panel meter/display at ZERO, the DVM should indicate 4 milliamps.

Electrical

1. Connect the 4-20 Module (five) 5 wire harness to the main circuit board at the location next to the display harness marked "4-20" as shown in figure III.A.4.
2. Connect the signal and power wires as required, as shown in figures III.A.1. & III.A.2. This assumes you

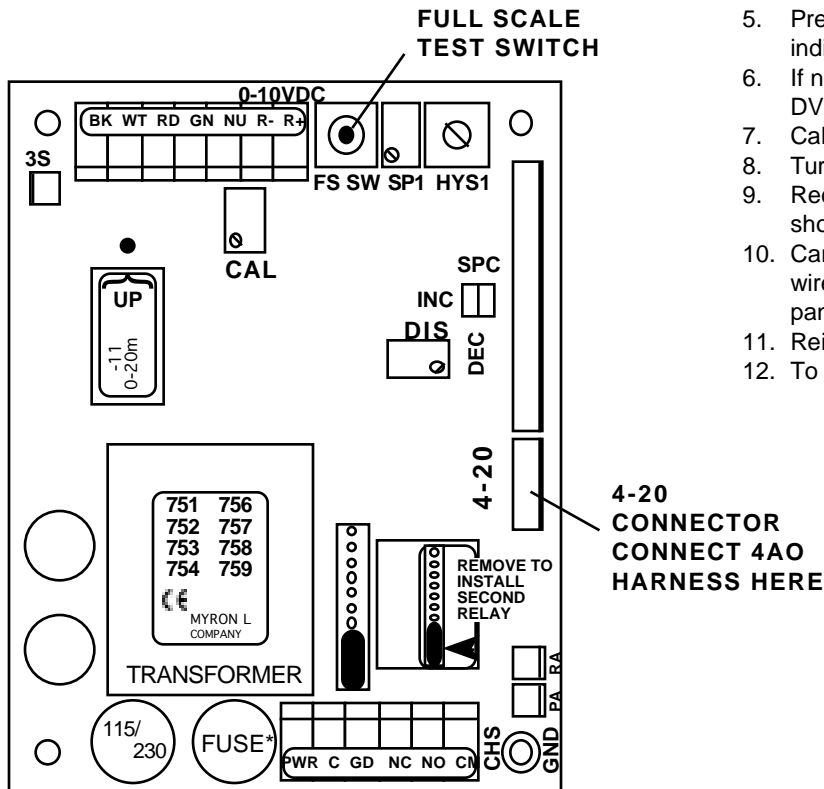

MONITOR/CONTROLLER CIRCUIT BOARD ASSEMBLY

Figure III.A.4.

4. If not, adjust the CAL control marked "4mA" until the DVM indicates 4mA, see figure III.A.5.
5. Press the Full Scale Test Switch, the DVM should indicate 20 milliamps.
6. If not, adjust the CAL control marked "20mA" until the DVM indicates 20mA. See figure III.A.5.
7. Calibration is complete
8. Turn power **OFF**.
9. Reconnect sensor wires to sensor terminal block as shown in figure III.A.4.
10. Carefully reinstall the front panel, bottom first, ensure no wires have been pinched between enclosure and front panel.
11. Reinstall the two (2) screws and tighten.
12. To operate, turn power **ON**.

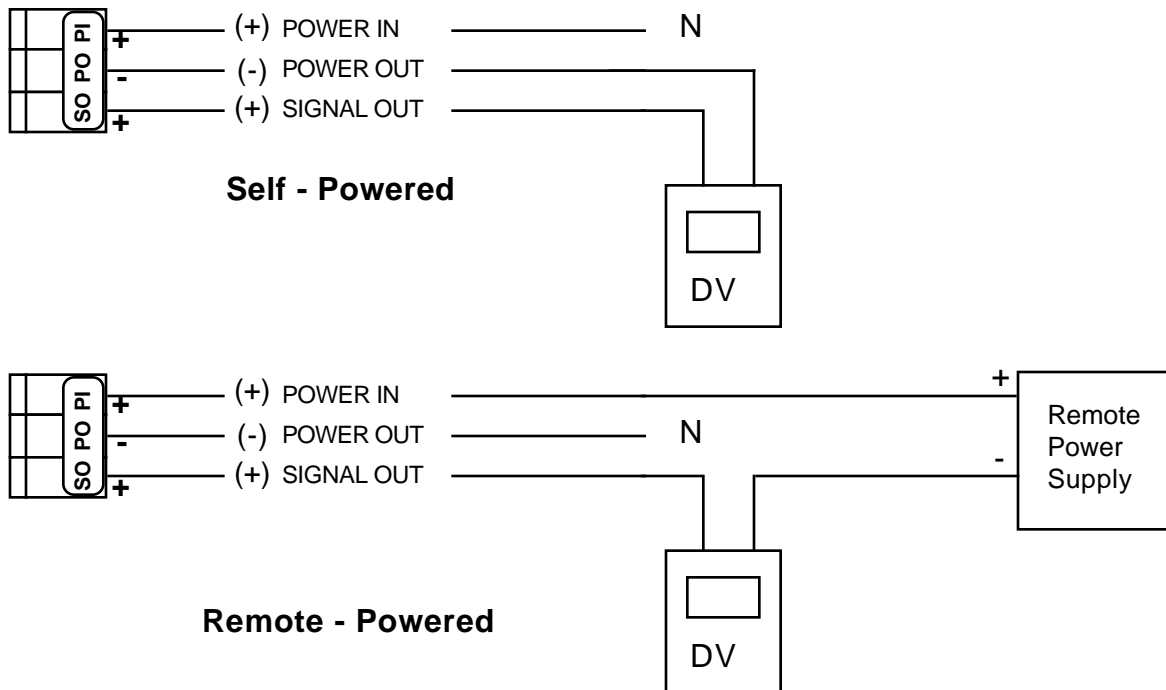

Figure III.A.5.

4. CONVERTING A CURRENT TO A VOLTAGE

Current measuring devices actually measure voltage, but have an internal resistor as shown in figures III.A.1 & III.A.2 and are scaled to display in current. If you have a voltage input instrument and you wish to utilize the current from the 4A (4-20mA) Module, the following will help you to make this conversion.

To convert a 4-20 mA current output to operate or drive a voltage input device it is necessary to install a LOAD resistor across the input terminals as shown in figures III.A.6 & III.A.7. The value of the resistor is chosen to match the input voltage range, i.e. 0-10 Volts requires a 500 resistor and will produce a 2 to 10 input voltage. This floating zero is useful to indicate a broken 4-20 input wire when the indication is zero volts.

For an input voltage range of:						
10.0 Volts	the resistor value is	500 ohms	indicates	2.0 V	@	4 mA.
5.0 Volts	"	250 ohms	"	1.0 V	"	"
1.0 Volts	"	50 ohms	"	0.2 V	"	"
100 millivolts	"	5 ohms	"	20 mV	"	"
10 millivolts	"	0.5 ohms	"	2 mV	"	"

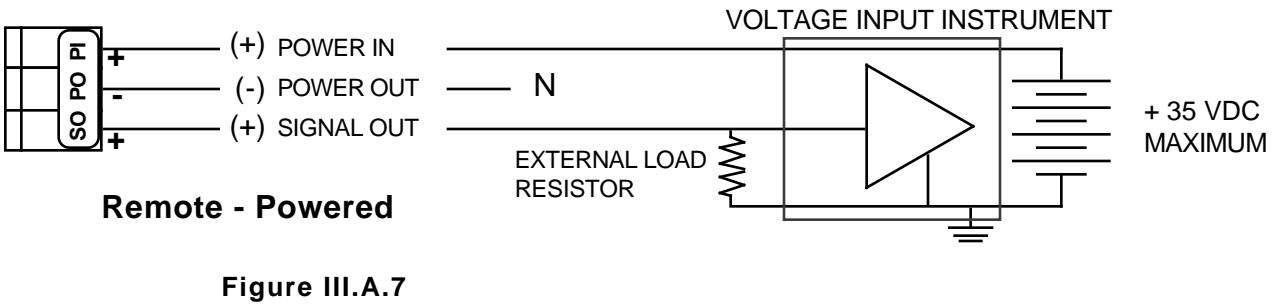
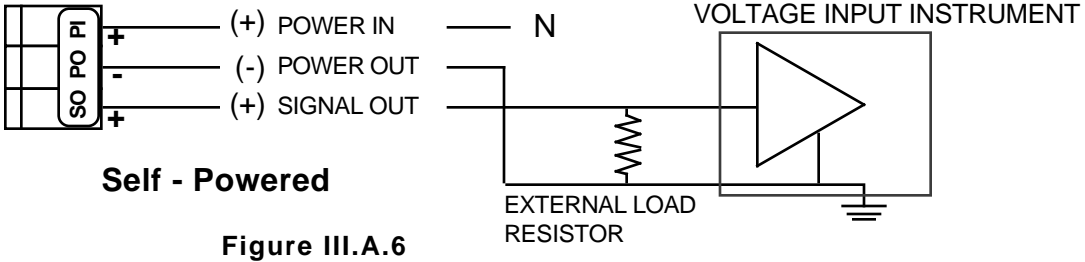

For other input ranges, divide the input voltage range by 0.02, the answer will be in ohms.

NOTE: The tolerance of the load resistor directly affects the accuracy of the resulting voltage, i.e. 5% resistor = 5% error.

B. PIEZO ELECTRIC ALARM

- PA Piezo Electric Alarm ordered with AQUASWITCH II.
- PAO Piezo Electric Alarm ordered separately for AQUASWITCH II.

1. DESCRIPTION

The PA/PAO is an electronic sound device capable of emitting a 80dB or more @ 30cm, high pitched squeal. See figure III.B.1.

Specifications

- Oscillating Frequency — 3.0 0.5KHz
- Operating Voltage — 24VDC Nom. (1.5-30VDC Max.)
- Sound Pressure Level (Min) 30cm/12VDC — 80dB
- Current consumption (Max) @ 12VDC — 12mA
- Tone — Constant
- Operating Temperature — -20 - +60°C
- Size — 24 x 9.5 mm



CAUTION - READ FOLLOWING CAREFULLY

WARNING: BEFORE STARTING, IF THE AQUASWITCH II IS INSTALLED, ENSURE THE POWER IS OFF. FAILURE TO DO SO COULD CAUSE DAMAGE TO THE INSTRUMENT, AND COULD BE HARMFUL OR FATAL TO PERSONNEL. ONLY QUALIFIED PERSONNEL SHOULD INSTALL OR SERVICE ELECTRICAL EQUIPMENT.

Physical

NOTE: Remote mounting will require a .25" (6.35mm) hole, and extending the harness. Use #22 gauge speaker wire. Observe polarity.

If the front panel has all ready been removed from the enclosure skip to #4.

1. Remove rubber plug as shown in figure III.B.2.
2. Using a standard slot screwdriver remove the two (2) screws on the front panel.

Double Backed Tape

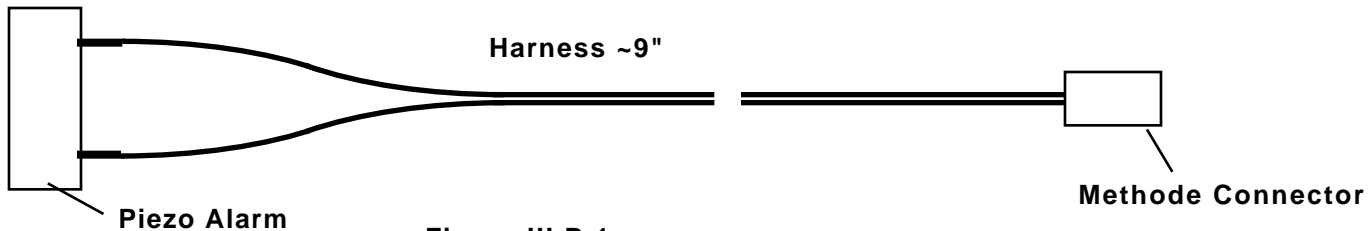
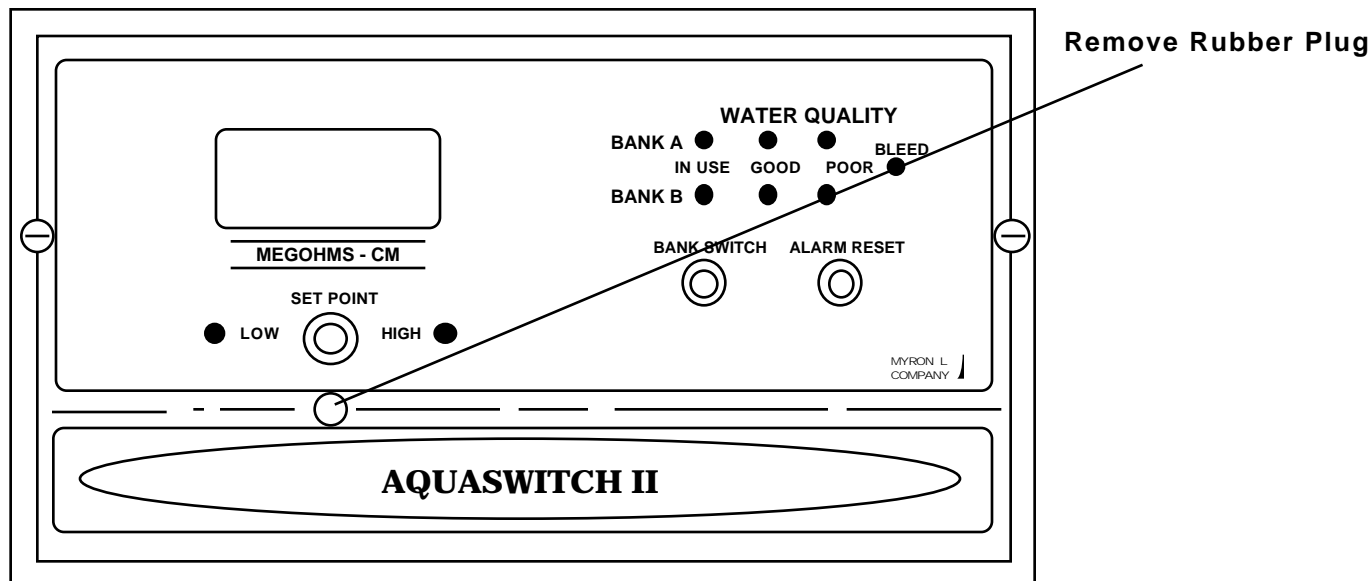

Figure III.B.1

2. INSTALLATION

Briefly -
 A rubber plug is removed from the front panel, figure III.B.2.
 The PA/PAO Piezo Alarm attaches to the front panel with the tape supplied, figure III.B.3.
 The wire harness plugs into a methode connector on the Main Monitor/controller circuit board, figure III.B.4.

3. Carefully wiggle the front panel and pull gently toward you. Do not pull more than about 8 inches/20CM or you could damage the wiring harness.
4. Turn the front panel around so that the back side is facing you.
5. Peel off tape backing from PA, and install as shown in figure III.B.3.
6. Set front panel aside.
7. Connect wire harness to Main Monitor/controller circuit board as shown in figure III.B.4.



AQUASWITCH II FRONT PANEL

Figure III.B.2

Test

1. Turn power **ON**. Depending on configuration, the Piezo will sound off when —.

NOTE: If the sensor is connected, the solution value, set point value and Set Point Conversion (SPC) jumpers may affect the test.

- a. For a Resistivity AQUASWITCH II, as shipped from the Myron L Company, the alarm will sound off when the power is applied and stop when the Full Scale Test Switch is pressed.
 - b. For a Conductivity/TDS AQUASWITCH II, as shipped from the Myron L Company, the alarm will sound off when the Full Scale Test Switch is pressed
 - c. If the Set Point Conversion (SPC) jumpers have been reversed, the opposite will be true in the above descriptions.
2. Turn power **OFF**.

REASSEMBLY

Before reassembly, ensure set point control is set to desired trip point.

1. Carefully reinstall the front panel, bottom first. Ensure no wires have been pinched between enclosure and front panel.
2. Reinstall the two (2) screws and tighten.
3. To operate, turn power **ON**.

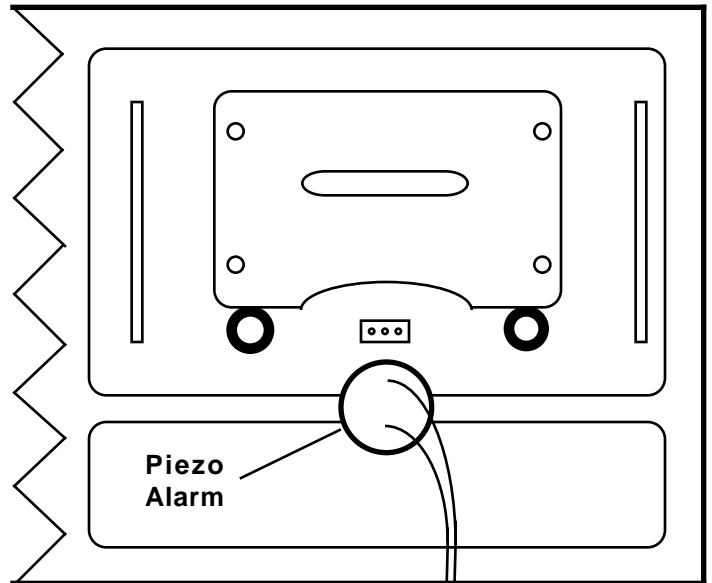

**AQUASWITCH II
FRONT PANEL
Rear View
Figure III.B.3**

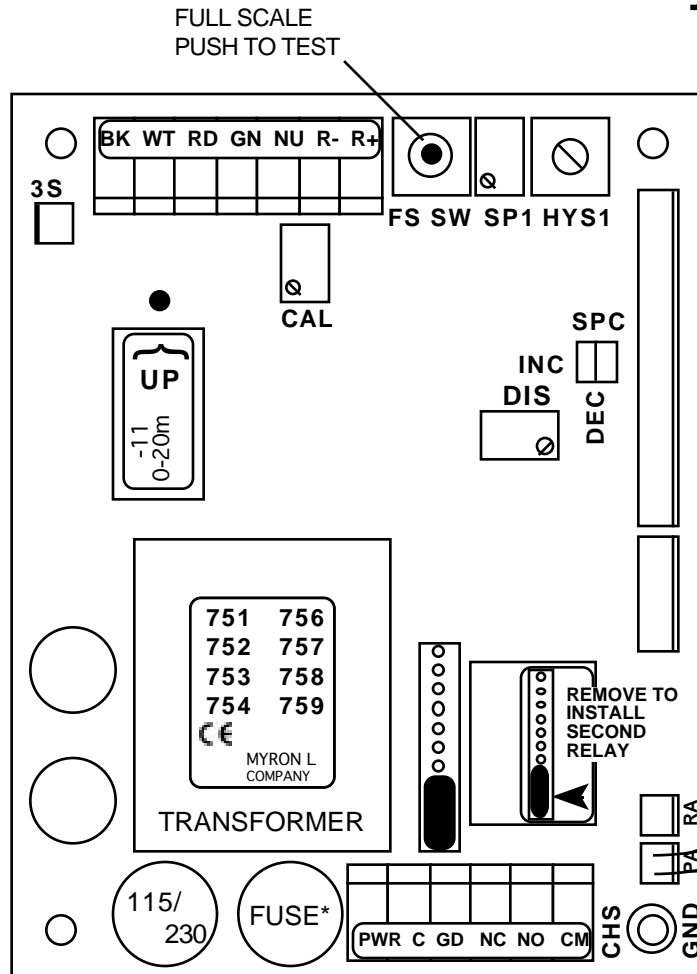

**MAIN MONITOR/CONTROLLER
CIRCUIT BOARD**

Figure III.B.4

**PA Connection
(may use either
connector)**

C. TEMPERATURE MODULE

- TP Temperature Module ordered with Monitor/controller.
- TPO Temperature Module Kit ordered separately.
Requires; CSXX-TP sensor, Special Order, i.e. CS10-TP or CS40-TP, see sensor data sheet.

1. DESCRIPTION

The Temperature Module (TP) gives the Monitor/controller more flexibility for the user by being in the same package. The Temperature Module is driven by the main display output and is very simple to install.

The Temperature Module and Temperature Sensor SYSTEM utilize a unique 3 wire technique by which errors are greatly reduced.

The Temperature Module has its own 0-5VDC output. TPO kit comes with all items necessary to install and operate: TP Module; front panel harness with switch, bezel, cap and two o-rings (006 & 008); and TEMPERATURE label (# LTEMP).

NOTE: Requires the CSXX-TP sensor temperature wires be routed directly to the TP/TPO CB.

Specifications

- ±200°C (±200°F Special Order Only)
- Accuracy: ±0.2 w/ICE ±0.5 w/out ICE
- Display Resolution = 0.1
- Output: 0-5 VDC Connections - 2
- Sensor Input: Cond/TDS, RES sensor with SPECIAL Platinum RTD added or 1000 RTD temperature sensor.
Connections - 3 (3 wire for increased accuracy over long distances)

Calibration

- Zero and Full Scale, FS (0 & 5 VDC): Factory Set Simple pots
- Display (CAL): Full Scale, FS (199.9) Factory Set Simple pot
- Operates on safe ±5 VDC supplied by the Main CB.

2. INSTALLATION

Briefly -

The Temperature Module replaces the plastic display retainer plate attached to the front panel. The display harness plugs into the Temperature Module instead of the display.

The -TP sensor leads are connected to the Temperature Module. See figure III.C.1.

The display switch is installed in the lower front panel as shown in figure III.C.4.

A "TEMPERATURE" label is added to lower front panel next to the Display Select switch as shown in figure III.C.4.



CAUTION - READ FOLLOWING CAREFULLY

WARNING: BEFORE STARTING, IF AQUASWITCH II IS INSTALLED, ENSURE THE POWER IS OFF. FAILURE TO DO SO COULD CAUSE DAMAGE TO THE INSTRUMENT, AND COULD BE HARMFUL OR FATAL TO PERSONNEL. ONLY QUALIFIED PERSONNEL SHOULD INSTALL OR SERVICE ELECTRICAL EQUIPMENT.

Physical

If the front panel has all ready been removed from the enclosure skip to 3.

1. Using a standard slot screwdriver remove the two (2) screws on the front panel.
2. Carefully wiggle the front panel and pull gently toward you. Do not pull more than about 8 inches/20CM or you could damage the wiring harness.
3. Turn the front panel around so that the back side is facing you.
4. Using a standard slot screwdriver remove the four (4) screws holding the plastic display retainer plate to the front panel. When the screws have been removed, the plastic display retainer plate and the display will be free from the front panel.
5. Set front panel down or carefully allow to hang from the harness. Do not drop as the harness connector will pull out allowing the front panel to fall.
6. While holding the display and the plastic display retainer plate, carefully remove the display harness connector. Do not drop the display.
7. Remove and discard the plastic display retainer plate.
8. Insert display connector pins into the Temperature Module female connector. See figure III.C.1.

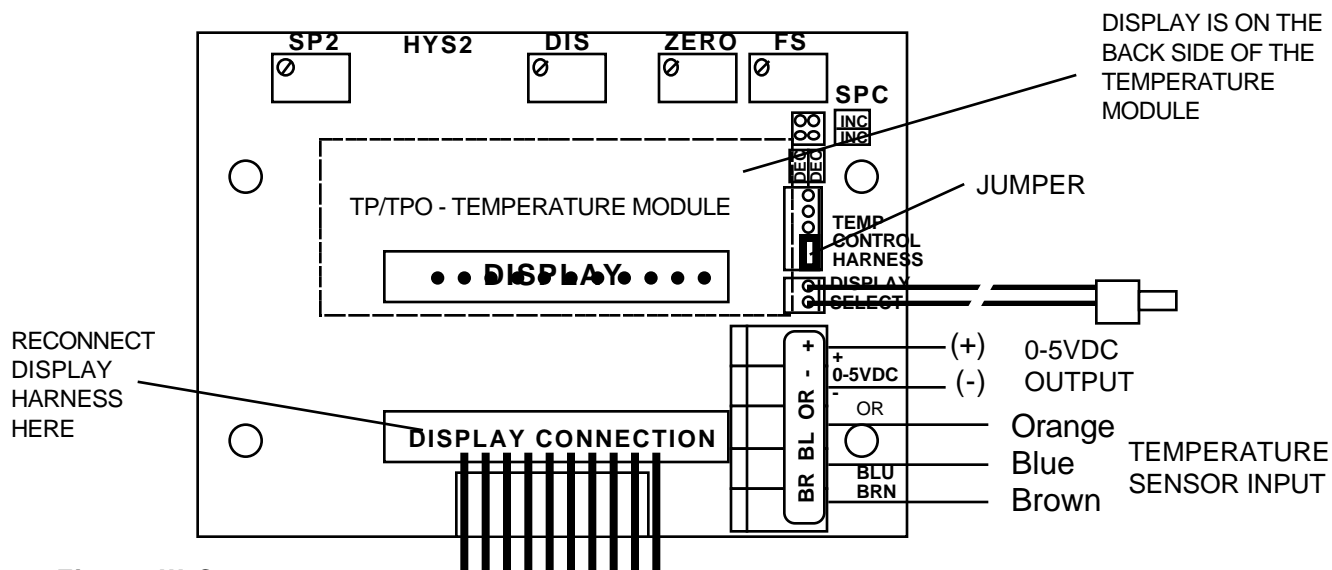

Figure III.C.1

9. While holding the front panel, align the display to the opening and at the same time, align the Temperature Module mounting holes to the front panel.
10. Reconnect display harness with leads down as shown in figures III.C.1 & III.C.2.
11. Reinstall the four (4) screws and tighten.

WARNING: There are two (2) o-rings installed on the switch, one (1) on the threaded shank and the other is under the push button. Both of these must be re-installed to maintain IP64/NEMA 3 ratings. See figure III.C.3.

4. Place "TEMPERATURE" label ABOVE the switch as shown in figure III.C.4.

Display Select Switch installation

1. Using a small sharp knife or 1/4" (6.35mm) drill, carefully cut open the lower center hole of the front panel, when viewed from the back. See figure III.C.2.
2. Install push-button display switch into this hole and tighten bezel. See figures III.C.2 & III.C.4.
3. Install push-button/cap on switch.

Electrical

1. Connect the display switch harness to the Temperature Module as shown in figure III.C.1.
2. Connect the Temperature Sensor leads to the Temperature Module as labeled in figure III.C.1.

CAUTION: The input connectors require only a small screwdriver or a pen to push on the release levers. The release levers may be broken or damaged if not pushed straight toward the CB. DO NOT push the release levers sideways. Follow the color code as labeled.

3. Connect 0-5 VDC output, if desired.
4. To test, turn power **ON**.
5. Press "TEMPERATURE" front panel switch, display will show the temperature of the sensor.
6. Turn power **OFF**.
7. Continue or reinstall the front panel and tightly secure both retaining screws, see REASSEMBLY below.

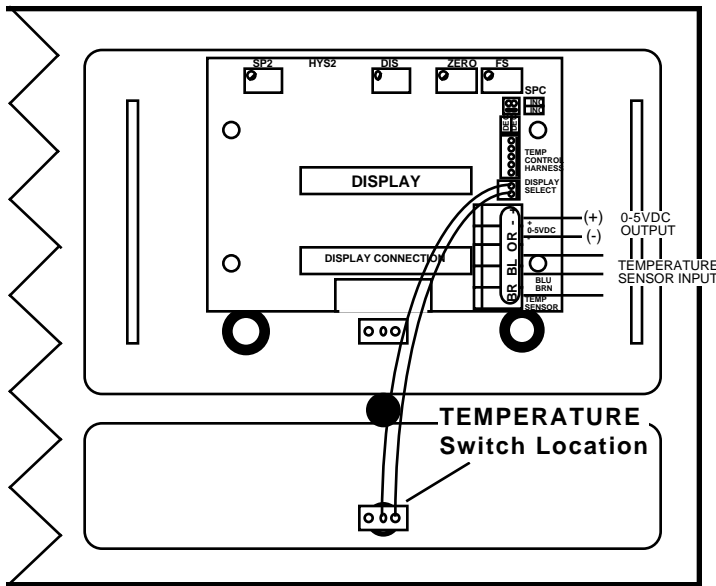

AQUASWITCH II FRONT PANEL Rear View

Figure III.C.2

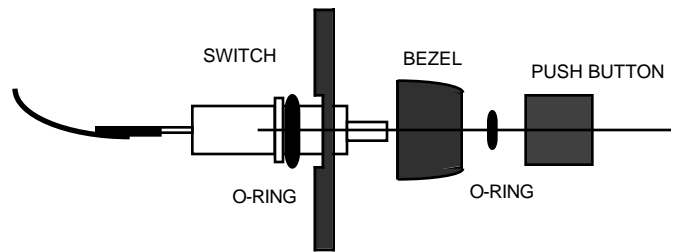

SWITCH and O-RING ASSEMBLY

Figure III.C.3

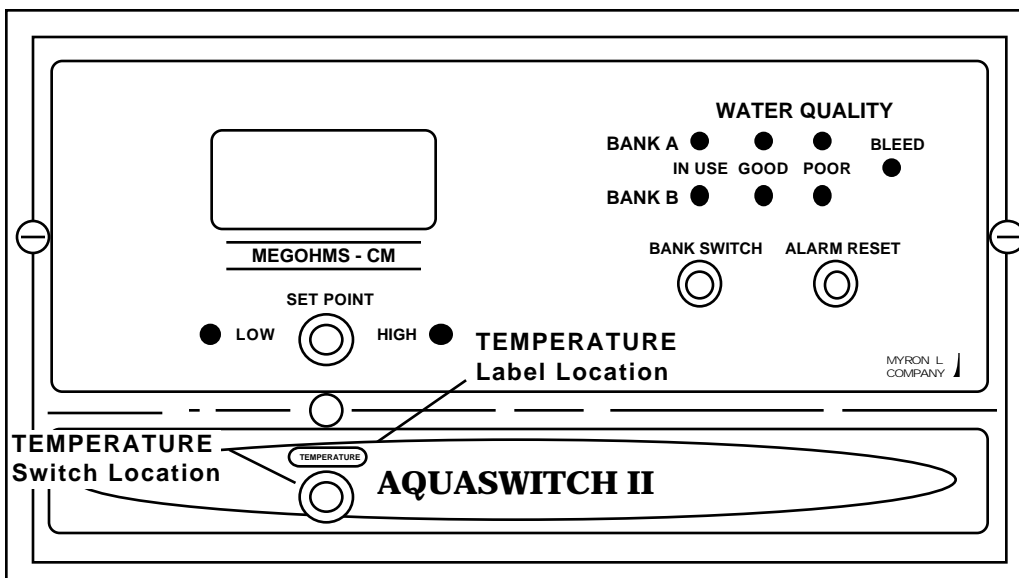

Figure III.C.4

3. RECALIBRATION

Electronic Calibration Only. For System Calibration, see below. The Temperature Module was calibrated at the factory, however, if you wish to check the calibration the following procedure will help you to accomplish this task. Exercise caution while performing this procedure.

Requirements:

TP Calibration Module (TPC) or

Two .1% precision resistors -

ZERO - 1000.0 (0°C = 0.0V)

SPAN - 1758.56 (200°C = 5.0V)

One (1) jumper

A DVM set to DC Volts, a tweaker or small standard slot screwdriver.

a. TPC "Calibration" Module Procedure

This procedure assumes the front panel is removed.

1. Ensure power is **OFF**.
2. Remove the sensor leads from the Temperature Module.
3. Remove the 0-5VDC leads from the Temperature Module.
4. Press TP Calibration Module (TPC) firmly into sensor input connectors as shown in figure III.C.5.
5. Attach the DVM to the 0-5VDC output on the TPC module. See figure III.C.6.
6. Turn power **ON**. The DVM should indicate **0.0** volts.
7. If not, adjust the calibration control marked "**ZERO**" (see figure III.C.1 for location) until the DVM indicates **0.0** volts as shown in figure III.C.5.
8. Press switch on the TPC. See figure III.C.6.
9. The DVM should indicate **5.0** volts. See figure III.C.6.
10. If not, while pressing the TPC Module switch, adjust the calibration control marked "**FS**" (see figure III.C.1 for location) until the DVM indicates **5.0** volts as shown in figure III.C.6.
11. Press the front panel TEMPERATURE select switch **and** the TPC Module switch, the display should indicate **199.9** as shown in figure III.C.7.

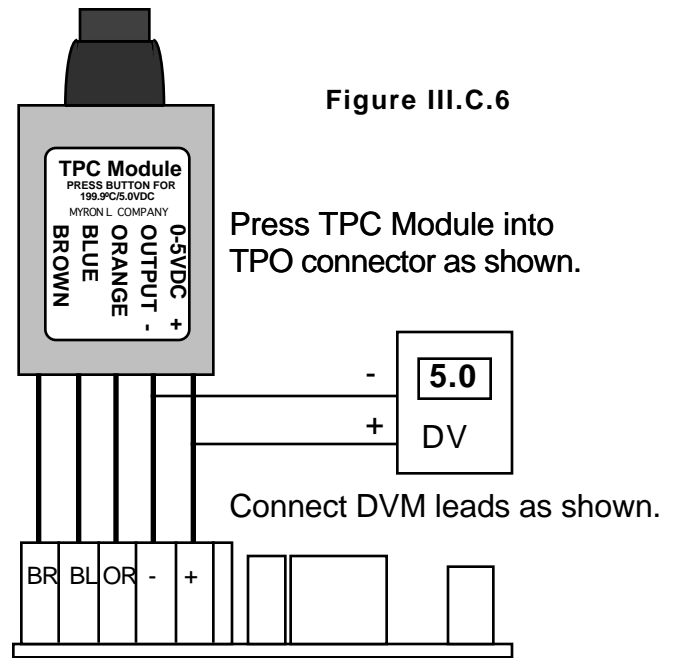
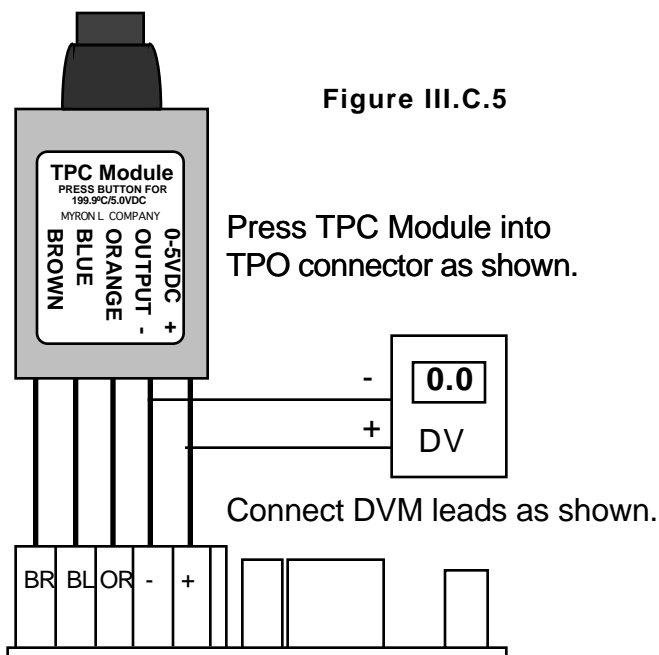

FRONT PANEL DISPLAY

Figure III.C.7

12. If not adjust the calibration control marked "**DIS**" (see figure III.C.1 for location) until the reading is **199.9** as shown in figure III.C.7.
13. Calibration is complete.
14. Turn power **OFF**.
15. Remove TPC Module by pressing on each Phoenix connector release lever*.
16. Reconnect sensor leads as labeled.
17. Reconnect 0-5 VDC output leads as labeled.
18. Continue or reinstall the front panel and tightly secure both retaining screws, see REASSEMBLY below.

***CAUTION:** The sensor input and 0-10 VDC output connectors require only a small screwdriver or a pen to push on the release levers. The release levers may be broken or damaged if not pushed straight toward the CB. DO NOT push the release levers sideways.

b. Precision Resistor Calibration Procedure

This procedure assumes the front panel is removed.

1. Ensure power is **OFF**.
2. Remove the sensor leads from the Temperature Module.
3. Install ZERO resistor (1000.0) across sensor terminals BL and OR. See figure III.C.8.
4. Install JUMPER between BR & BL as shown in figures III.C.8 & III.C.9.
5. Attach the DVM to the 0-5 VDC output. See figures III.C.8 & III.C.9.
6. Turn power **ON**. The DVM should indicate **0.0** volts.

7. If not, adjust the calibration control marked "ZERO" (see figure III.C.1 for location).
8. Install SPAN resistor (1758.56) across sensor terminals BL and OR. See figure III.C.9.
9. The DVM should indicate 5.0 volts.
10. If not, adjust the calibration control marked "FS" (see figure III.C.1 for location) until the DVM indicates 5.0 volts as shown in figure III.C.9.
11. Press the front panel TEMPERATURE select switch, the display should indicate 199.9 as shown in figure III.C.10.
12. If not adjust the calibration control marked "DIS" (see figure III.C.1 for location) until the reading is 199.9.
13. Calibration is complete.
14. Turn power **OFF**.
15. Remove DVM from 0-5 VDC.
16. Remove resistor and jumper by pressing on each Phoenix connector release lever*.
17. Reconnect sensor leads as labeled.
18. Reconnect 0-5 VDC output leads as labeled.
19. Continue or reinstall the front panel and tightly secure both retaining screws, see REASSEMBLY below.

***CAUTION:** The sensor input and 0-5 VDC output connectors require only a small screwdriver or a pen to push on the release levers. The release levers may be broken or damaged if not pushed straight toward the CB. DO NOT push the release levers sideways.

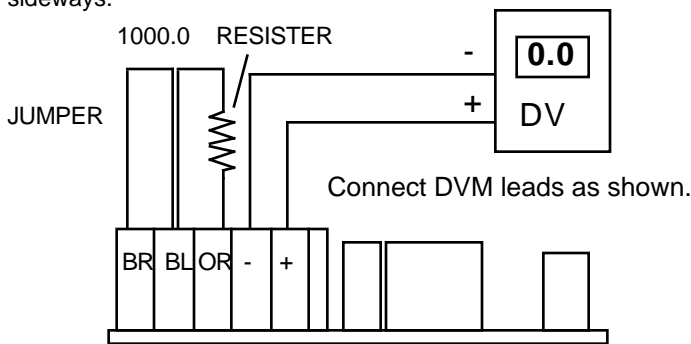

Figure III.C.8

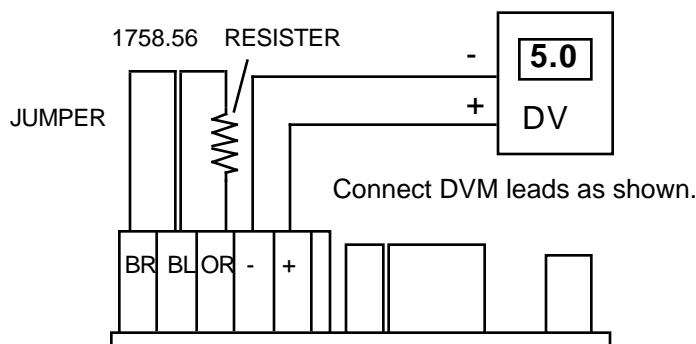

Figure III.C.9

199.9

FRONT PANEL DISPLAY

Figure III.C.10

c. System Calibration

By following these steps the complete temperature system, module and sensor, may be calibrated to better than $\pm 0.2^\circ$ centigrade accuracy. This procedure is similar to the electronic calibration except the sensor is attached and is allowed to equilibrate in "ICE" water before adjusting the ZERO calibration control.

NOTE: One of the above electronic calibration procedures, TPC Module or precision resistors, must be performed BEFORE the system calibration is performed. This is required to preset the span between zero and full scale.

1. Ice must be crushed in water to form a very thick slurry. A slurry is that condition where the water to ice ratio is such that only sufficient water is present to allow easy stirring. At this point, the temperature of the water will be 0.000°C.
2. Immerse sensor and cable approximately 2" (50mm) into slurry.
3. Allow to equilibrate. Slurry must be constantly stirred.
4. Continue stirring until no further change in temperature is observed on the display.
5. Adjust TP Module ZERO calibration control to 000.0.
6. Continue or reinstall the front panel and tightly secure both retaining screws, see REASSEMBLY below.

REASSEMBLY

1. Carefully reinstall the front panel, bottom first. Ensure no wires have been pinched between enclosure and front panel.
2. Reinstall the two (2) screws and tighten.
3. To operate, turn power **ON**.

D. REMOTE ALARM - RA™

RA Ordered as an accessory, includes 8" harness with connector, and two (2) wire nuts.

1. DESCRIPTION

This remotely mounted AUDIBLE and VISUAL alarm connects to any Myron L Company AQUASWITCH II Monitor/controller, or brand "X" controller with dry contacts. When activated by the controller the Remote Alarm will provide both an audible and a visual alert at a location other than at the controller.

A mute button will silence the piezo alarm for up to 10 minutes while the LED remains illuminated. After the preset time the piezo alarm will again sound, this will repeat until the water quality is corrected. Thus allowing servicing of the system under control, while still acting as a reminder if the problem has not been corrected.

The Remote Alarm - RA™ is an inexpensive way to alert personnel of a trouble situation. For example; the Monitor/controller may be located with an RO system while the service technicians are on another floor or even in another building - great for hospitals. The AUDIBLE alarm may be silenced, but stays in alarm (RED LED is still illuminated) until the trouble is corrected. The timer may be set from 15 seconds up to 10 minutes, thereby, giving personnel the time to correct the problem while not being able to ignore the trouble because of the reoccurring AUDIBLE and VISUAL alerts.

Specifications

Audible Alert — Piezo Electric

Oscillating Frequency — 3.0±0.5KHz

Operating Voltage (750II) — 24 VDC Nom. (1.5-30VDC Max.)

Sound Pressure Level (Min) 30cm/12VDC — 80dB

Current consumption (Max) @ 12 VDC — 12mA

Tone — Constant

Operating Temperature — -20 - +60°C

Size — 24 x 9.5 mm

Visual Alert — Bright RED LED

Time Delay — 15 seconds to 10 minutes (USER adjustable)

Power — 24 VDC (supplied from Monitor/controller)

Case Material — ABS plastic

Dimensions — 4.75L x 2.56W x 1.56H (121L x 65W x 40H)

Mounting — Double Backed Tape (supplied)

Operational Distance — Wire lengths of 500 feet (152 meters) have been tested with no adverse effects

Additional Wire available, order RAW-200. — 200 feet (61 meters)

2. INSTALLATION

Briefly —

Only 2 wires to connect from the controller to the RA.

Set the time.

Mount on the wall or on the bench.



CAUTION - READ FOLLOWING CAREFULLY

WARNING: BEFORE STARTING, IF THE AQUASWITCH IS INSTALLED, ENSURE THE POWER IS OFF. FAILURE TO DO SO COULD CAUSE DAMAGE TO THE INSTRUMENT, AND COULD BE HARMFUL OR FATAL TO PERSONNEL. ONLY QUALIFIED PERSONNEL SHOULD INSTALL ELECTRICAL EQUIPMENT.

The Remote Alarm - RA connector is labeled **24 VDC INPUT** and has a 8" 2 conductor wires attached — Black is Positive (+) and White is Negative (-).

When extending the wires you may use any two color wire you wish just remember the polarity — Black is Positive (+) and White is Negative (-). Wire lengths of 500 feet/152 meters have been tested and have no adverse effect on performance although a length of 500 feet/152 meters would be unusually long.

Ensure the unit is completely wired, tested and adjusted before installing RA to mounting surface as the tape will not remove from mounting surface without damaging the adhesive.

For OEM models skip steps referencing enclosure or front panel.

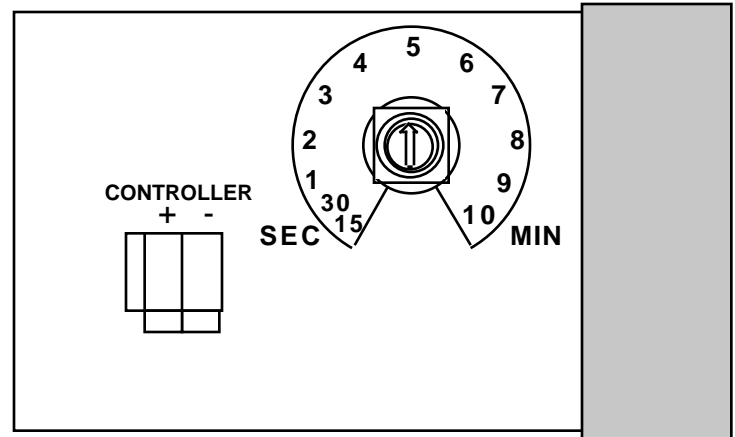

RA CB ASSEMBLY

Figure III.D.1

1. Run #22, 2 conductor speaker type wire, NOT supplied, from Monitor/controller to RA location as necessary. Wire may be ordered from the Myron L Company, part #RAW-200.
2. Open the RA by removing the four screws.
3. Locate and remove the 8" 2 conductor wire with the reddish brown connector attached to the RA. See figure III.D.1.
4. At the RA, connect the extension wires to the connector on the RA circuit board — Black to Positive (+) and White to Negative (-) as shown in figure III.D.1.
5. Using a standard slot screwdriver remove the two (2) screws on the Myron L Monitor/controller front panel.
6. Carefully wiggle the front panel to loosen the gasket and pull gently toward you. Do not pull more than about 8 inches/20CM or you could damage the wiring harness.
7. Connect the extension wires to the 8" 2 conductor wire with the wire nuts provided — Black to Positive (+) and White to Negative (-). Be sure to first pass the wire through the user supplied waterproof strain relief in the enclosure.
8. Plug the reddish brown connector into the male connector on the controller circuit board marked RA (see inside case label or figure III.D.2 for location). It will only go on the connector one way.
9. To test, simply turn **ON** the controller and adjust controller set point until the alarm sounds off*. If controller is not yet connected to water, on conductivity/TDS controllers it will be necessary to press and hold the Full Scale Test Switch. See figure III.D.2. The black button on the front of the RA will mute the piezo

alarm for approximately three minutes or until you improve the water quality (readjust controller set point). If three minutes muting is fine for your application, skip to #10.

10. If three minutes is too long or too short, adjust control inside RA until desired mute time is achieved (adjustable from approximately 15 seconds to 10 minutes). see figure III.D.1.
11. Replace the bottom of the RA, and secure to surface you have selected for its installation.
12. Carefully reinstall the controller front panel, bottom first. Ensure no wires have been pinched between enclosure and front panel.
13. Reinstall the two (2) screws and tighten.
14. To operate, turn power **ON**.

***NOTE:** If the RA does not sound off;

1. Check the polarity of the extension wire connections.
2. Be sure the controller is actually switching (relay will click).

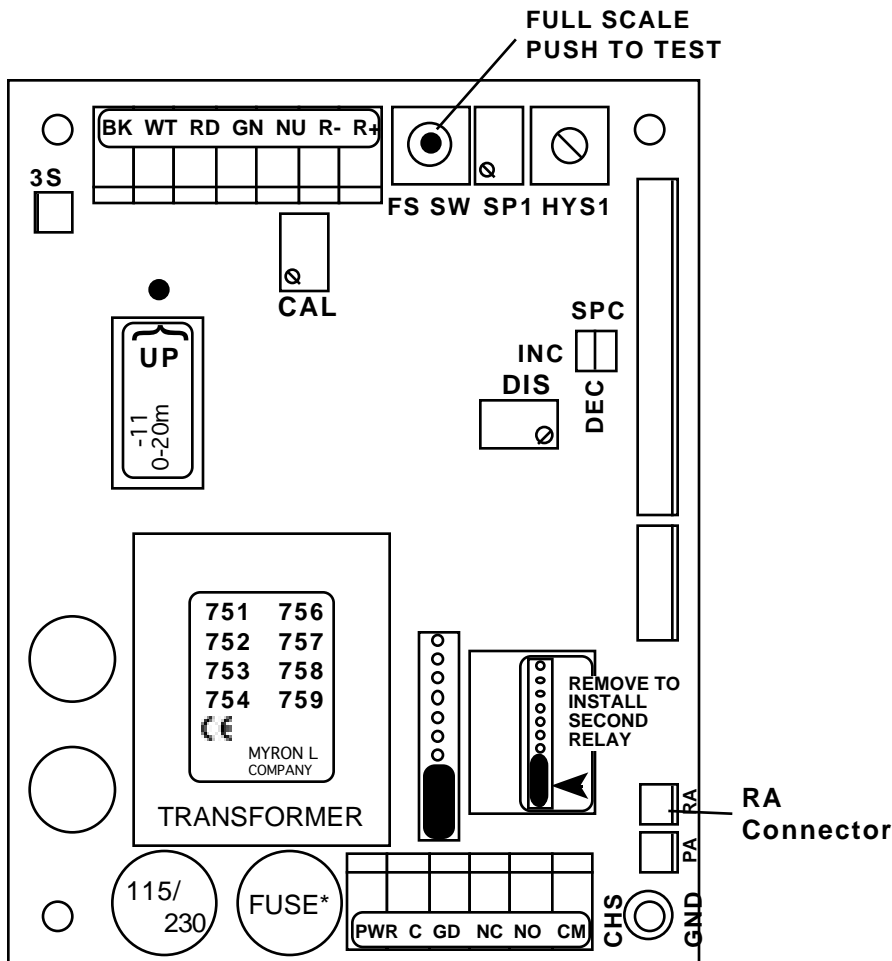

**MAIN MONITOR/CONTROLLER
CIRCUIT BOARD**

Figure III.D.2

IV. OPERATING PROCEDURES

The front panel illustrations, switch and indicator operational descriptions have been provided to assist the user in identifying and operating the AQUASWITCH I & AQUASWITCH II Monitor/controllers.

Section IV.A provides the operational descriptions for each of the AQUASWITCH I and AQUASWITCH II switch and indicator controls.

Section IV.B provides the user with recommended Setup procedures

Section IV.C provides the user with recommended checkout procedures.

A. SWITCH AND INDICATOR CONTROLS

1. AQUASWITCH I

BANK A/B "IN USE" Indicators

The amber "IN USE" LED indicator light is ON only when its respective Bank's solenoid valve is energized.

NOTE: The units have been designed so that only one (1) Bank (either A or B) can be in use at any time.

Water Quality "GOOD" Status Indicators

The green "GOOD" status LED light indicators are ON when their respective Bank's water quality is acceptable or ABOVE Controller Set Point - Resistivity (the reverse is true for Conductivity - BELOW).

Water Quality "POOR" Status Indicators

The red "POOR" status LED light indicators are ON only when their respective Bank's water quality is unacceptable or BELOW Controller Set Point - Resistivity (the reverse is true for Conductivity - ABOVE).

"BLEED" Indicator Light

The amber "BLEED" LED indicator light is ON only when the AQUASWITCH is in its Purge Cycle (Bleed/Process Water valve(s) are activated).

"BANK SWITCH" Push Button

When the "BANK SWITCH" is pressed, the AQUASWITCH automatically switches Banks, i.e. turns OFF the currently selected Bank and turns ON the alternate Bank, i.e. Bank A to Bank B or visa versa.

"ALARM RESET" Push Button

When the-"ALARM RESET" switch is pressed, the AQUASWITCH will automatically turn OFF the Alarm.

2. AQUASWITCH II

The AQUASWITCH II incorporates all of the features listed above in the AQUASWITCH I plus those listed below.

3 1/2 Digit LCD

The 3 1/2 Digit LCD provides a continuous readout of the water being controlled. A 3 1/2 digit "backlit" LCD is available as an option.

"HIGH/LOW" Set Point Indicators

The green LED indicator light is ON only when the resistance of the water is ABOVE the Controller's internal Set Point.

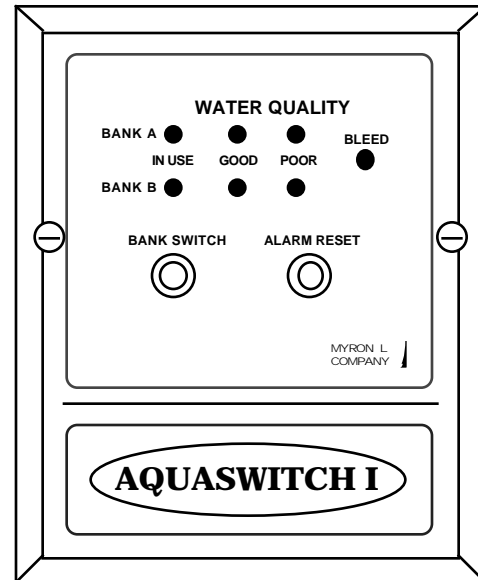

AQUASWITCH I FRONT PANEL

Figure IV.A.1

The red LED indicator light is ON only when the resistance of the water is BELOW the Controller's internal Set Point.

NOTE: The reverse is true for Conductivity.

"SET POINT CHECK" Switch

When the "SET POINT CHECK" switch is pressed, the internal Set Point reading is immediately displayed on the LCD.

3. AQUASWITCH II OPTIONS

Piezo Alarm

Audible alarm sounds off automatically when the set point is reached. Figure IV.A.2. shows the location of this option. See section III.B.

Backlit Display

A 3 1/2 digit "backlit" LCD is available.

Temperature Module adds the ability to momentarily display the solution temperature by pressing a switch mounted on the from panel as shown in figure IV.A.2. see section III.C for details.

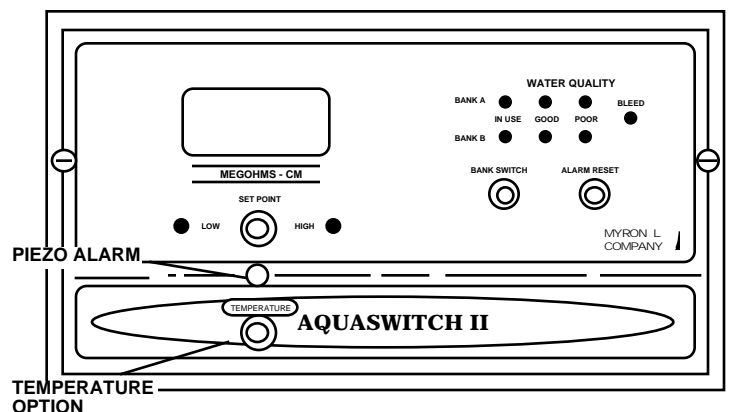

AQUASWITCH II FRONT PANEL

Figure IV.A.2



CAUTION - READ FOLLOWING CAREFULLY

B. SETUP PROCEDURES

These Setup procedures cover (1) converting the alarm circuit to trigger on a decreasing (conductivity) or increasing (Resistivity) reading, (2) setting the alarm circuit set point, and (3) adjusting the hysteresis.

The following require that the front panel be removed. While doing so be careful not to strain the cable(s).

NOTE: A small screwdriver or tweaker will be required for several of the following operations.

1. SET POINT CONVERSION (SPC) / REVERSING SET POINT

The alarm/control circuit on all Resistivity AQUASWITCH II Monitor/controllers are configured to trigger the alarm relay as the Resistivity reading decreases.

The alarm/control circuit on all Conductivity/TDS AQUASWITCH II Monitor/controllers are configured to trigger the alarm relay as the conductivity/TDS reading increases.

If the user's application requires it, the alarm circuit may be easily reconfigured to trigger the alarm relay as the conductivity (or ppm) reading decreases or increases for Resistivity. Refer to figure V.A.1. for the locations of the jumpers referred to in this section.

NOTE: These instructions describe the general procedures for converting the AQUASWITCH II Monitor/controller without reference to jumper numbers or orientation.

1. Ensure power is **OFF**.
2. Locate the jumper block for the alarm to be configured.
3. Make a note of the current orientation of the jumpers.
4. Remove both jumpers. This is easily done by hand. Take care not to crush the jumpers if using pliers.
5. Rotate the jumpers 1/4 turn and reinstall them on their posts as shown in figure IV.B.1.

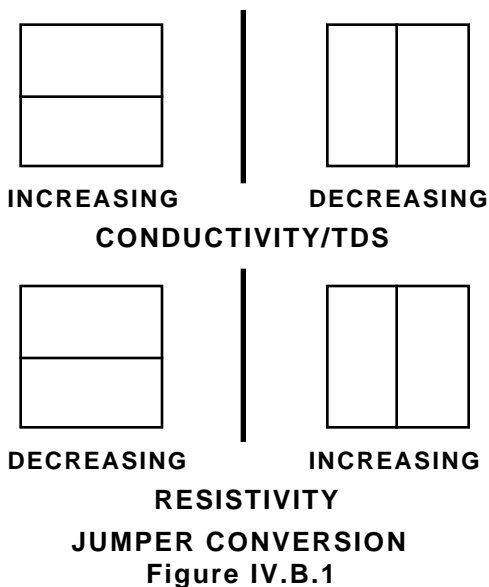

2. SET POINT ADJUSTMENT

The set point setting is based upon the user's particular water purity specifications or requirements.

1. Being careful not to strain the cable, unfasten and remove the Monitor's front panel.
2. While depressing the "SET POINT" switch, turn the Set Point #1 adjustment screw (See figure V.A.1) until the desired set point value is indicated on the display.
3. If Hysteresis adjustment is required see below. If not, reinstall the front panel and tightly secure both retaining screws.

3. HYSTERESIS (DEAD BAND) ADJUSTMENT

The hysteresis or dead band is approximately ±3% of the set point at full scale as it leaves the factory. Under normal (most) conditions it will not be necessary to adjust.

However, if you desire to make an adjustment please keep the following in mind.

The adjustment is very simple and is based on set point location. If the set point* is in the upper 75-100% of the scale, the hysteresis control pot should be turned fully to the right.

If the set point is in the lower portion of the scale, i.e. 5-25% of scale, the control pot may be turned fully to the left.

If you are operating in the center, 25-75% of scale, the the control pot may be adjusted in the center.

Or the hysteresis or dead band may be adjusted to tighten the control of a particular process.

CAUTION: adjusting the hysteresis too tight may cause the alarm to fluctuate (on-off) due to flow, chemical mixing or bubbles causing the relay to chatter. This condition is to be avoided, it could damage your valves, pumps, etc. and will eventually damage the relay.

The following is assuming the front panel is already removed and the set points have been set, if not see above.

1. Locate the hysteresis control adjustment located next to the Set Point #1 (SP1) adjustment - it is a single turn pot. See figure V.A.1.
2. Adjust as described above or as desired.

C. OPERATIONAL CHECKOUT PROCEDURES

The following checkout procedures are used to verify that the AQUASWITCH I or AQUASWITCH II is operating properly. To complete the checkout procedure, it is assumed that the system is fully installed and the AQUASWITCH I is connected to a reliable Monitor/controller or an AQUASWITCH II is installed. It is also assumed that two fresh DI banks or RO system are on line with the system and the Monitor/controller is indicating water quality in the desired range.

During this test procedure, it will be necessary to simulate GOOD and POOR water quality. This is done by setting the Set Point to BELOW or ABOVE the Monitor/controller's actual water reading. When the Set Point is set BELOW (counterclockwise), the monitor will simulate "GOOD" water quality. "POOR" water quality is simulated by setting the Set Point ABOVE (clockwise) the actual water quality.

1. AQUASWITCH II (ONLY)

For AQUASWITCH II users, the term "Controller" refers to the ASII Monitor/controller Circuit Board functions.

1. Using the "SET POINT CHECK" switch, verify that the display indicates the desired Set Point.

NOTE: If the display does not indicate the correct Set Point setting, reference Section IV.B.2 and figure V.A.1 for the procedures to readjust the AQUASWITCH II's internal Set Point.

2. Observe reading of water being monitored.
3. With front panel removed, press "SET POINT CHECK" switch and observe the reading on the display. With a small screwdriver, adjust the Set Point trimmer (See figure V.A.1) to above the reading observed in step 2.
4. Release the "SET POINT CHECK" switch and observe that the red "POOR" light is ON.
5. Press the "SET POINT CHECK" switch and adjust screw adjustment until the Set Point is below the reading observed in step 2.
6. Release the "SET POINT CHECK" switch and observe that the green "ABOVE" light is ON. Also note the audible click of the relay as the lights change.
7. Readjust the Set Point adjustment to the desired Set Point setting and replace front panel. This completes the AQUASWITCH II Monitor/controller Board checkout.

2. AQUASWITCH I and AQUASWITCH II

For AQUASWITCH II users, the term "Controller" refers to the ASII Monitor/controller Circuit Board functions.

1. Turn the Purge Cycle trimmer adjustment screw fully clockwise to obtain an approximate one minute cycle. (See figure V.A.1)
2. Adjust Controller "Set Point" to simulate "GOOD" water quality (for the AQUASWITCH II, turn the Set Point trimmer adjustment screw counterclockwise (see Section IV.B.2 and See figure V.A.1)) and verify the following sequence of operation.
3. Push "BANK SWITCH" several times to verify the following Controller operations.
 - a. Verify that the "IN USE" indicator lights switch ON and OFF between Banks A and B each time "BANK SWITCH" is pressed.
 - b. Verify that both Banks A/B "GOOD" water quality lights remain ON.
 - c. Verify that the "BLEED" light remains OFF.
 - d. Leave BANK A ON for next step. (If required, push the "ALARM RESET" switch to reset alarm.)

NOTE: If the Logic Module Alarm Reset jumper has been installed to provide the user with the optional Manual Bank Switch alarm condition, the alarm will be activated each time the "BANK SWITCH" is pressed. Otherwise, the alarm will be activated only when the Purge Cycle time setting has expired. (Refer to Section V.C)

4. Adjust Controller Set Point to simulate "POOR" water quality. (For the AQUASWITCH II, turn Set Point trimmer adjustment screw clockwise, and verify the following sequence of operation.)
 - a. BANK A water quality indicates "POOR."
 - b. Yellow "BLEED" light turns ON and water is purged from system. (This should continue for about 1 minute.)
 - c. After 1 minute, BANK A will turn OFF and BANK B will turn ON and indicate "POOR" water quality.
 - d. After approximately 1 minute, BANK B should turn OFF, the "BLEED" light should turn OFF, the Bleed

valve should close and the alarm should be activated. The system is now entirely shut down.

NOTE: If an external alarm is connected, it will be activated when the AQUASWITCH switches Banks. (Press the "ALARM RESET" switch to turn OFF alarm.)

If an alarm is not connected, an alarm condition can be monitored by connecting an ohm meter (DVM) across Power Board Alarm Terminals COM and NO. The meter should indicate a CLOSED CIRCUIT when in the alarm condition.

5. Adjust the Controller Set Point to simulate "GOOD" water quality. (For the AQUASWITCH II, turn Set Point trimmer adjustment screw counterclockwise and verify the sequence of operation.)
6. Press the "BANK SWITCH." The BANK A "IN USE" and "GOOD" water quality indicator lights should turn ON. Press the "BANK SWITCH" again and BANK B "IN USE" and "GOOD" water quality indicator lights should turn ON.
7. Complete the following steps to return the AQUASWITCH to its normal operating status.
 - a. Using the "BANK SWITCH," select the desired Bank "IN USE" status.
 - b. Adjust the Controller "Set Point" to the desired minimum water quality. (Refer to Section IV.B.2 and figure V.A.1.)
 - c. Set Purge Cycle to the desired time delay. (Refer to Section V.B)

REASSEMBLY

1. Carefully reinstall the front panel, bottom first. Ensure no wires have been pinched between enclosure and front panel.
2. Reinstall the two (2) screws and tighten.
3. To operate, turn power **ON**.

V. COMPONENT IDENTIFICATION, CALIBRATION AND PREVENTIVE CARE

This section provides detailed illustrations to assist the user in identifying the AQUASWITCH I and AQUASWITCH II primary components and cable connector designations.

Section A. Provides the user with the Primary Component Identification.

Section B. Provides the user with the Purge Cycle Calibration Procedure.

Section C. Provides the user with the Alarm Reset Mode Calibration Procedure.

Section D. Provides the user with the AQUASWITCH II Calibration Procedures.

Section E. Provides the user with the Myron L Company recommended Preventive Care Procedures.

Section F. Provides the user with Alternative Valve Configurations.

A. PRIMARY COMPONENT IDENTIFICATION

As identified in Section IV, the AQUASWITCH I and AQUASWITCH II switch and indicator components are mounted directly to the front panel.

The AQUASWITCH I Power Board is contained within and mounted to the back of the enclosure.

The AQUASWITCH II Main Monitor/controller Circuit Board and Power Board are mounted to the back of the enclosure. Some models with options have an additional circuit board mounted behind the front panel, i.e. Model ASIIR-4A (4-20 Module).

Review figure V.A.1 below to familiarize yourself with the different circuit board and component locations.

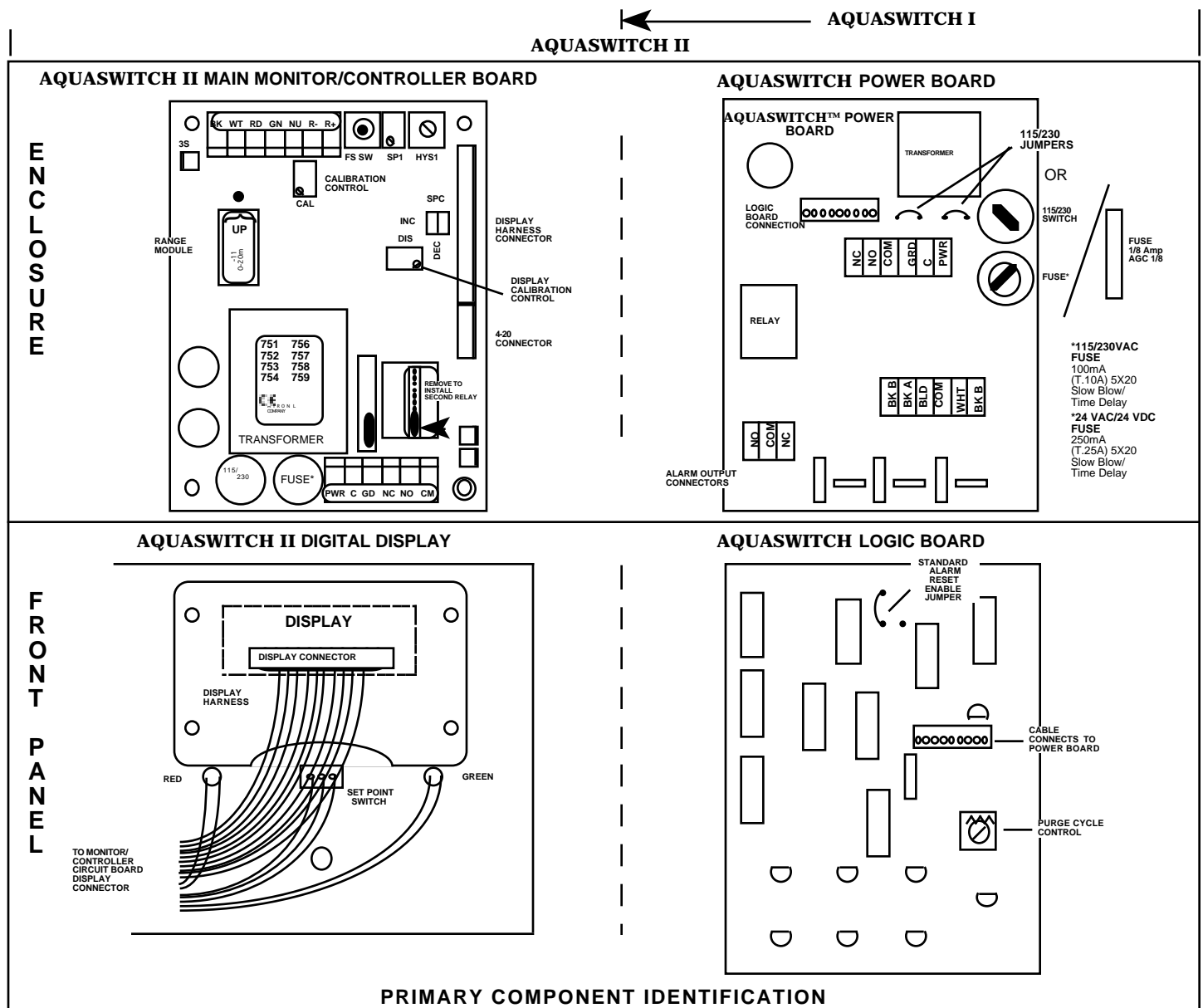

Figure V.A.1

B. "PURGE CYCLE" CALIBRATION PROCEDURE

The Purge Cycle control adjustment (see figure V.A.1) determines the time span that the Bleed and Process solenoid valves are energized during either a Bank A or B Purge Cycle. Turning the adjustment screw fully clockwise equals a minimum Purge Cycle of approximately one (1) minute. Turning the adjustment screw fully counterclockwise equals a maximum Purge Cycle of nine (9) to thirteen (13) minutes.

1. Being careful not to excessively strain the cable(s), unfasten the enclosure's front panel.
2. Turn the Logic Board adjustment to the desired Purge Cycle setting. See figures V.A.1 and V.B.1.

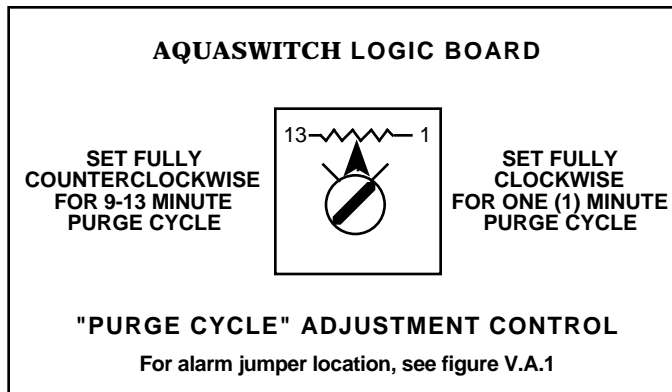

Figure V.B.1

C. "ALARM RESET" MODE CHANGE PROCEDURE

The AQUASWITCH I and AQUASWITCH II are shipped with an Alarm condition that occurs whenever the "IN USE" Banks are switched automatically.

This section provides the user with the procedures for activating an Alarm condition every time the "BANK SWITCH" is manually pressed.

NOTE: The Manual Bank Switch alarm condition is in addition to the standard Automatic Bank Switch alarm condition.

To activate the Manual Bank Switch alarm condition, the user must reinstall the Logic Module Alarm Reset jumper as shown in figure V.C.1.

1. Being careful not to excessively strain the cable(s), unfasten the enclosure's front panel.
2. Remove the Logic Board Jumper and reinstall as shown in figure V.C.1.

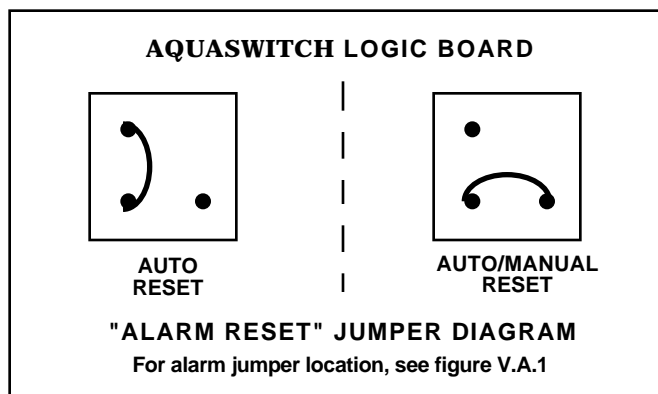

Figure V.C.1

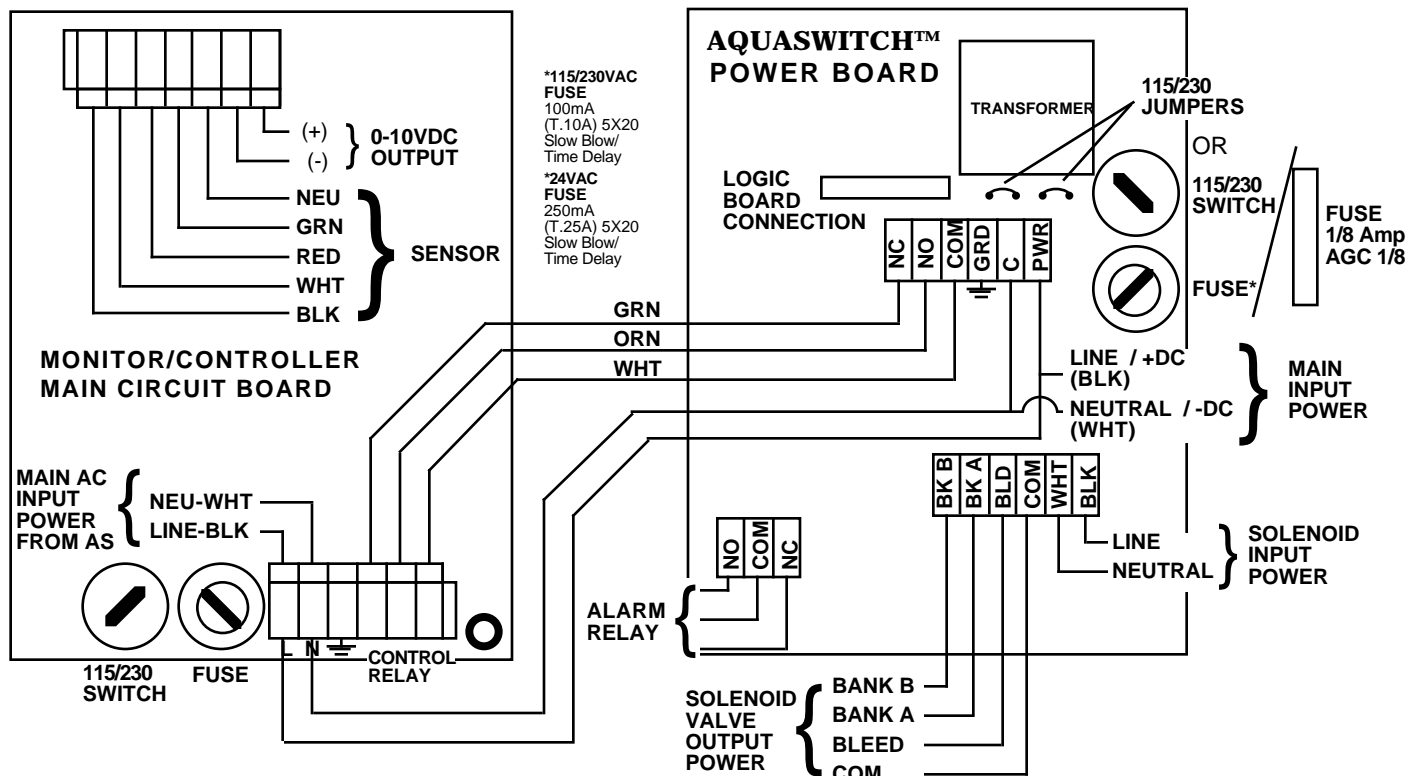

Figure V.A.2

AQUASWITCH II™ ELECTRICAL CONNECTION DIAGRAM



CAUTION - READ FOLLOWING CAREFULLY

D. CALIBRATION PROCEDURES

AQUASWITCH I does not require calibration.

All Myron L AQUASWITCH II Monitor/controllers are factory calibrated prior to shipping and are ready to install without further calibration. Calibration should be checked occasionally with the internal Calibration/Full Scale Test switch (FS SW) to ensure continued accuracy. The following procedures are provided in the event that recalibration becomes necessary. The only equipment required are a tweaker or small screwdriver, and standard solution.

Refer to Figure V.A.1. to locate the components described in this section.

NOTE: When opening instrument, remove front cover with care; a ribbon cable connects the front panel and main board.

When performing calibration procedures, the technician must take extreme care to avoid contacting the circuitry other than the CALibration control. Failure to do so could result in damage to the equipment, property and/or personal injury.

1. ELECTRONIC CALIBRATION (CIRCUIT ONLY)

This method is faster than the following method using standard solution, but it does not include the sensor. Therefore, it should be used only in applications where the chance of sensor contamination or damage are slight.

NOTE: The **DIS**play calibration control has been **set** and **sealed** prior to leaving the factory, and under normal conditions will not require readjustment. This allows the customer to use the panel meter/display to easily set the electronic Full Scale value. If the **DIS**play calibration control has been adjusted it will be necessary to, first, verify or adjust the Full Scale using a DVM as described in "Full Scale Calibration" below, followed by adjusting the **DIS**play calibration control to Full Scale on panel meter/display.

a. Full Scale Calibration

1. Ensure power is **OFF**.
2. Using a standard slot screwdriver remove the two (2) screws on the front panel.
3. Carefully wiggle the front panel to loosen the gasket and pull gently toward you. Do not pull more than about 8 inches/20CM or you could damage the wiring harness.
4. Turn the front panel around so that the back side is facing you and set aside.
5. Turn power **ON**.
6. Press and hold the Full Scale Test switch. The display should indicate Full Scale for the particular range selected, i.e. 0-50 ppm should indicate 50. If not, set to Full Scale with the CALibration control.

NOTE: When setting digital models with a full scale of 2000 (1999), it is advisable to adjust Full Scale to 1990, otherwise an overrange condition may occur.

7. Turn power **OFF**.
8. Re-install front panel as described below in "REASSEMBLY" or continue.
9. To operate, turn power **ON**.

b. 0-10VDC Recorder Output Calibration

For output voltages other than 10VDC, substitute as required, i.e. 5.00VDC or 2.00VDC per Section II.F.2.

Requires a DVM set to DC Volts.

1. Ensure power is **OFF**.
2. Attach DVM to RECORDER output connection.
3. Turn power **ON**.
4. Press and hold the Full Scale Test switch (FS SW).
5. The DVM should indicate 10.00VDC.
6. If not, adjust **CAL**ibration control until DVM indicates 10.00VDC.
7. Verify the panel meter/display, it should indicate Full Scale reading as shown on Range Module.
8. If not, adjust **DIS**play control until a full scale reading is displayed. When setting digital models with a full scale of 2000 (1999), it is advisable to adjust Full Scale to 1990, otherwise an overrange condition may occur.
9. Turn power **OFF**.
10. Re-install front panel as described below in "REASSEMBLY" or continue.
11. To operate, turn power **ON**.

2. CALIBRATION USING STANDARD SOLUTION

The best method of recalibrating your conductivity/TDS AQUASWITCH II Monitor/controllers is with NIST traceable Standard Solution (available from the Myron L Company). Because it includes the sensor, the entire system is recalibrated.

NOTE: Since standard solution calibrations are NOT practicable with Resistivity models, another means of verification or calibration of resistivity models is to use the transfer standard method, using a hand-held or portable instrument capable of resistivity measurements, i.e. the Myron L Ultrameter™. See section V.D.4 description.

The following procedure describes the easiest method for standard solution calibration of your Conductivity/TDS Monitor/controller.

1. Using a standard solution which is 60-90% of full scale of the instrument, i.e. for 0-20 μ S range use KCl-18, rinse thoroughly and fill a clean glass beaker with the standard solution.
2. Place sensor in the beaker of standard solution. The level of standard solution must be high enough to cover at least 1/2" above cross hole.
3. Slowly shake the sensor to remove air bubbles from inside the sensor bore hole.
4. Allow 5-10 minutes for temperature to equilibrate. For the quickest and the best results, both the sensor and solution should be at the same temperature.
5. Turn power **ON**.
6. Read the display of the instrument. The display should match the value and units of measure located on the bottle of standard solution. If the reading is different, adjust **CAL**ibration control on the main circuit board until the reading matches the solution value. This will require removal of the front panel. For removal, see section V.D.1.a, 1-4.
7. After adjustment, turn power **OFF**.
8. Re-install front panel as described below in "REASSEMBLY".
9. To operate, turn power **ON**.

3. SENSOR SUBSTITUTE CALIBRATION

NIST traceable Sensor Substitutes are commonly used to verify and calibrate Resistivity Monitor/controllers. Normally they are not needed due to the “built-in” electronic calibration or “Full Scale Test”. However, your requirements may be such that a crosscheck or verification is required. Sensor Substitutes are available from the Myron L Company, see accompanying chart, figure V.D.1, for part number.

If the proper Resistivity Sensor Substitute is not readily available and you can not wait for one to be delivered, one may be constructed using the equivalent resistor values listed on the accompanying chart, figure V.D.1 and schematic, figure V.D.2.

NOTE: If you have previously performed a system calibration with either a NIST Standard Solution, or using the transfer standard method, using this procedure will make that calibration invalid. You must decide which is more important, a system calibration, or an electronic calibration.

1. Ensure power is **OFF**.
2. Using a standard slot screwdriver remove the two (2) screws on the front panel.
3. Carefully wiggle the front panel and pull gently toward you. Do not pull more than about 8 inches/20CM or you could damage the wiring harness.
4. Turn the front panel around so that the back side is facing you and set aside.
5. Locate and remove the sensor leads from the sensor connector as shown in figure V.A.3.
6. Install Sensor Substitute with label toward transformer as shown in figure V.D.3.
7. Turn power **ON**.

RESISTIVITY MONITOR/CONTROLLER		
RANGE	PART NUMBER	RESISTER VALUE - X*
0-20 MΩ	CS-11	1 MΩ
0-10 MΩ	CS-12	50 KΩ
0-5 MΩ	CS-13	20 KΩ
0-2 MΩ	CS-14	100 KΩ
0-1 MΩ	CS-15	5 KΩ
0-500 KΩ	CS-16	24.9 KΩ
0-200 KΩ	CS-17	10 KΩ

*1%

Figure V.D.1

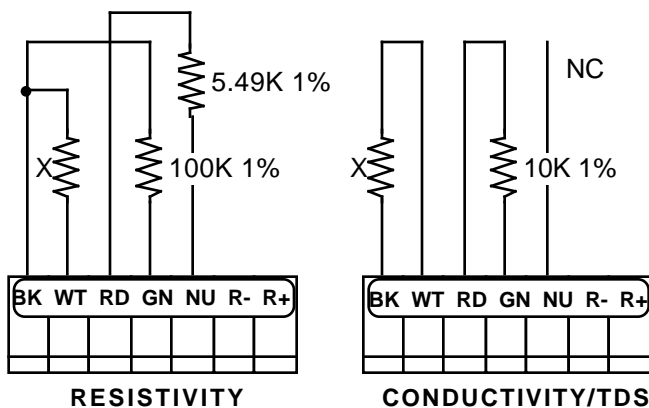

Figure V.D.2

8. Display reading should be full scale of range. If not, adjust **CAL**ibration control to read full scale, i.e. 0-50 K range should indicate 50, 0-10.00 M = 10.00, and 0-20.00 M = 20.00 at full scale.
9. After adjustment, turn power **OFF**.
10. Re-install front panel as described below in “REASSEMBLY”.
11. To operate, turn power **ON**.

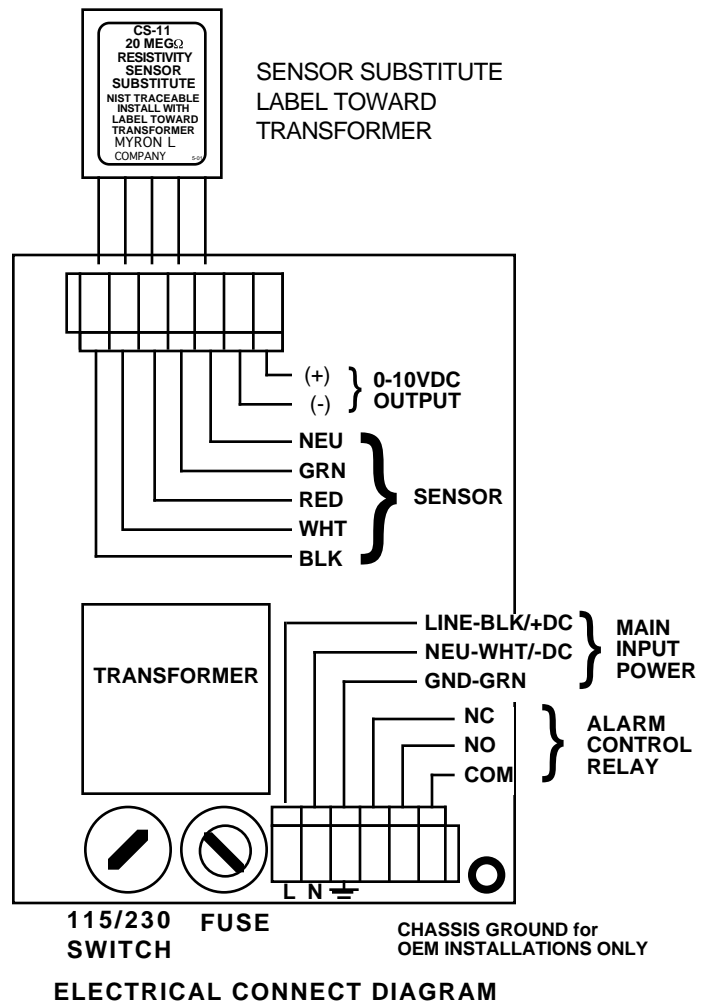

Figure V.D.3

4. TRANSFER STANDARD METHOD

For maximum accuracy of any AQUASWITCH II Monitor/controllers, the transfer standard method should be utilized. Instead of removing the entire Monitor/controller and sensor, and either returning it to the manufacture or sending it to a third party laboratory for recertification, the transfer standard allows quick recertification and return to service — less down time. While being the most accurate method it is also very easy to perform, and may be used to calibrate ANY manufacture Monitor/controller — resistivity or conductivity/TDS. This method still has the benefit of third party verification, if so desired.

1. A high quality hand-held instrument, one capable of accurate conductivity/TDS and/or “resistivity” readings such as the Myron L Ultrameter™, is calibrated using a standard solution, or if so desired, sent to a third party laboratory for calibration & certification. Preferably the standard solution should be as close as practicable to

the area of the AQUASWITCH II Monitor/controllers operation, i.e. for a conductivity AQUASWITCH II Monitor/controllers that is operating between 15 and 20 μ S, the recommended Myron L standard solution is KCI-18.

NOTE: For resistivity values, the Myron L Company can supply NaCl standards as low as ~25 μ S on special order. Extremely low values are available from other sources. Calibrated at 25 μ S the Ultrameter is capable of very accurate resistivity measurements.

2. Once the Ultrameter is calibrated, the process water is measured. (For resistivity measurements, follow the recommended procedure described in the Ultrameter Operation Manual, section IV.B, Measuring Resistivity.)
3. Finally, the AQUASWITCH II Monitor/controllers is calibrated/adjusted to match the value measured by the Ultrameter by adjusting the Main **CAL**ibration control shown in figure V.A.1.
4. Turn power **OFF**.
5. Re-install front panel as described below in "REASSEMBLY".

REASSEMBLY

1. Carefully reinstall the front panel, bottom first. Ensure no wires have been pinched between enclosure and front panel.
2. Reinstall the two (2) screws and tighten.
3. To operate, turn power **ON**.

E. PREVENTIVE CARE

The Myron L Company recommends that the following Preventive Care procedures be observed.

1. Try to prevent exposure to excessive heat and moisture.
2. The AQUASWITCH II Monitor/controllers's main AC power source should be protected against excessive voltage "spikes."
3. Take care not to damage the Monitor during handling.

NOTE: Daily, weekly or monthly maintenance schedules are based upon the frequency of use and the severity of the Monitor's environment and operating conditions.

4. Repeat the AQUASWITCH II Monitor/controllers's Check-Out procedures to verify satisfactory operation and/or isolate possible troubleshooting symptoms.
5. Check all cable connections to ensure that they are free of moisture and contamination.
6. Inspect and replace damaged component boards and cable assemblies.
7. Periodically remove, clean and inspect the Sensor (ASII).

F. ALTERNATIVE VALVING CONFIGURATIONS & OPERATION for CONTINUOUS PROCESS WATER

The following methods will provide an uninterrupted water supply to process if a fresh DI bank is NOT in place when the other DI bank exhausts. Refer to figures II.A.1, II.E.1 & II.E.2.

OPTION 1

Requirements:

Continuous process. No interruptions allowed.

Connections:

"A" output (BANK A) to "A" valve AND "B" valve.

"B" output not connected.

Bleed not connected.

Omit bleed valve.

Configure "A" valve Normally Closed & "B" valve Normally Open.

OPTION 2

Requirements:

Continuous process. Holding tank between DI beds and process.

Purge ok but no prolonged shutdown.

Connections:

Bleed output (BLEED) connected to bleed valve.

Bleed configured as Normally Closed.

Other connections same as Option 1.

OPTION 3

Requirements:

Continuous process. Purge required only at system startup.

Connections:

Same as Option 2.

Add manual valve in line with Bleed Valve.

VI. OPTIONS & ACCESSORIES

A. OPTIONS ORDERED WITH MONITOR/CONTROLLER

<u>PART #</u>	<u>DESCRIPTION</u>
-4A	4-20mA Self-Powered Isolated Output Module (ASII only)
-PA	Piezo Electric Alarm (ASII only)
-35BL	3 1/2 Digit Backlit Liquid Crystal Display (ASII only)
-TP	Temperature Module 0-200°C, Requires -TP Sensor (ASII only)
-PC	Powercord 115 VAC (8 ft. with USA plug and Strain Relief) - NOT for 230 VAC use.

SPECIAL ORDER OPTIONS

-24VA	24 VAC Isolated Power
-24VD	24 VDC Isolated Power
-PTS	Front Panel Full Scale Test Switch (ASII only)
-TPA	Temperature Module 0-200°C WITH Adjustable Hysteresis, Requires -TP Sensor (ASII only)

B. OPTIONS & ACCESSORIES ORDERED SEPARATELY

<u>PART #</u>	<u>DESCRIPTION</u>
4AO	4-20mA Self-Powered Isolated Output Module (ASII only)
PAO	Piezo Electric Alarm Only (ASII only)
35BLO	3 1/2 Digit Backlit Liquid Crystal Display (LCD) (ASII only)
TPO	Temperature Module 0-200°C, Requires -TP Sensor (ASII only)
TPC	Calibration Module (Temperature Module)
PCO	Powercord 115 VAC (8 ft. with USA plug and Strain Relief) - NOT for 230 VAC use
SMP50	Surface Mounting Plate for AQUASWITCH I with two (2) 1/4-20 x 3/8 screws
SMP60	Surface Mounting Plate for AQUASWITCH II with two (2) 1/4-20 x 3/8 screws
RA	Remote Alarm - RA™ (ASII only)
RAW200	Wire, 200 ft/60 meters, Remote alarm
VR	Powersupply, 24 VAC, 20VA. (115 VAC, Indoor use Only)
024-1	24 VAC 1" Solenoid Valve
CS-11	20 Megohm Resistivity Calibration Module (Sensor Substitute) NIST Traceable
CS-14	2 Megohm Resistivity Calibration Module (Sensor Substitute) NIST Traceable
CS-17	20 Kilohm Resistivity Calibration Module (Sensor Substitute) NIST Traceable
CC or CR	NIST Certificate without Sensor C = Conductivity/TDS, R = Resistivity
CCS	NIST Certificate with Sensor in Standard Solution

C. STANDARD SOLUTIONS & BUFFERS

1. CONDUCTIVITY/TDS STANDARD SOLUTIONS

Your Conductivity/TDS Monitor/controller has been factory certified to meet certain specifications based on the appropriate Myron L Company NIST traceable standard solutions. These same solutions are available to you.

DESCRIPTION

The Myron L Company manufactures three basic types of conductivity/TDS standard solutions — KCl, NaCl and 442™. See below.

Most Myron L standard solution bottles show three values referenced at 25°C:

Conductivity in microsiemens/micromhos, while the ppm/TDS equivalents are based on our 442 Natural Water™, and NaCl standards. All standards are within ±1.0% of reference solutions.

These same buffers may be used for calibration and recertification of your Myron L or other handheld instrument.

a. Potassium Chloride (KCl)

The concentrations of these reference solutions are calculated from data in the International Critical Tables, Vol. 6.

b. 442 Natural Water™

442 Natural Water Standard Solutions are based on the following salt proportions: 40% sodium sulfate, 40% sodium bicarbonate, and 20% sodium chloride which represent the three predominant components “anions” in freshwater. This salt ratio has conductivity characteristics approximating fresh natural waters and was developed by the Myron L Company over three decades ago. It is used around the world for measuring both conductivity and TDS in drinking water, ground water, lakes, streams, etc.

c. Sodium Chloride (NaCl)

This is especially useful in sea water mix applications, as sodium chloride is its major salt component. Most Myron L standard solution labels show the ppm NaCl equivalent to the conductivity and to ppm 442 values.

2. pH and ORP BUFFER SOLUTIONS

For your pH and/or ORP Monitor/controller. Your pH and ORP Monitor/controller requires the same care and calibration as your Conductivity/TDS Monitor/controller. With the following Myron L Company NIST traceable buffer solutions it is possible for you to maintain the accuracy required in your process.

NOTE: pH and/or ORP Monitor/controllers ORP ZERO is calibrated using 7pH buffer. SPAN may be calibrated using any high quality ORP mV solution.

These same buffers may be used for calibration and recertification of your Myron L or other handheld instrument.

a. pH Buffer Solutions

pH buffers are available in pH values of 4, 7 and 10. Myron L Company buffer solutions are traceable to NIST certified pH references and are color-coded for instant identification. They are also mold inhibited and accurate to within ±0.01 pH units @ 25°C. Order 4, 7 or 10 Buffer.

b. pH Sensor Storage Solution

Myron L Storage Solution prolongs the life of the pH sensor. It is available in quarts and gallons. Order SSQ or SSG.

ALL standard solutions and buffers:

\$16.00US per quart/liter

\$58.00US per gallon

Prices as of July 1, 2001. Subject to change—call for latest prices.

Order example: 442-3000QT
KCL-7000GAL

C.1.a. Potassium Chloride Standards

KCl-18

KCl-180

KCl-1800

KCl-18,000

KCl-70

KCl-700

KCl-7000

KCl-70,000

C.1.b. 442 Natural Water Standards

442-15

442-150

442-1500

442-15,000

442-30

442-300

442-3000

442-30,000

442-500

442-1000

C.1.c. Sodium Chloride Standards

NaCl-12.5

NaCl-13.4

NaCl-14.0

C.2.a. pH Buffer Solutions

pH4.0

pH7.0

pH10.0

C.2.b. pH/ORP Storage Solution

SSQ - Quart/liter

SSG - Gallon

Customer Standard Solutions available by special order @ \$90.00 per Gallon. Contact us with your request.

VII. REPLACEMENT PARTS

PRICES AS OF July 1, 2001

PRICES SUBJECT TO CHANGE — contact the Myron L Company for the latest prices.

Prices are in US dollars.

<u>PART #</u>	<u>CIRCUIT BOARD ASSEMBLIES</u>	<u>PRICE</u>
XXX	AQUASWITCH I & AQUASWITCH II Power Board	\$XXX.00
XXX	AQUASWITCH I & AQUASWITCH II Logic Board	\$XXX.00
753IIRB	ASIIR RESISTIVITY Monitor/controller Circuit Board	\$301.00
758IICB	ASIIC CONDUCTIVITY Monitor/controller Circuit Board	\$290.00
(Must select RANGE MODULE from RANGE SELECTION GUIDE, see page 8)		NO ADDITIONAL CHARGE
24VA	24 VAC Isolated Power, add to above prices	\$18.00
24VD	24 VDC Isolated Power, add to above prices	\$45.00
If VOLTAGE is not specified 115/230 VAC will be supplied.		
<u>RANGE MODULES</u> SELECT from RANGE SELECTION GUIDE, see page 8		
RMXXX	Range Module Only	\$16.00
RMXXXD	With Overlay Labels	\$18.00
<u>DIGITAL DISPLAYS</u>		
35	3 1/2 Digit without Bezel	\$70.00
35BL	3 1/2 Digit Backlit without Bezel	\$130.00
<u>HARNESS (STANDARD 9 in./229 mm)</u>		
XX	Harness, Power to Logic Board	\$XX.00
DH	Harness, ASIIR or ASIIC Monitor/controller	\$73.00
<u>ENCLOSURE</u>		
ASIEC	AQUASWITCH I Rear Housing (BOX)	\$36.00
ASIEC	AQUASWITCH II Rear Housing (BOX)	\$XX.00
<u>FRONT PANEL</u> with UPPER and LOWER LABELS ONLY		
ASIFP	AQUASWITCH I Front Panel	\$60.00
ASIFP	AQUASWITCH II Front Panel	\$XX.00
<u>OPTIONS & ACCESSORIES</u>		
4AMO	4-20mA Self-Powered Isolated Output Module	\$108.00
4AH	Harness, 4A (4-20mA)	\$32.00
TPMO	Temperature Module 0-200°C	\$116.00
TPAMO	Above Temperature Module with Adjustable Hysteresis (SPECIAL ORDER)	\$118.00
TDH	Harness, TP and TPA (Temperature Module)	\$44.00
TPC	Calibration Module (Temperature Module)	\$119.00
F100	Fuse, 115/230 VAC Monitor/controller & Power Board (late), 100mA (T.10A) 5 X 20 Slow Blow/Time Delay	\$2.00
F250	Fuse, 24 VAC Monitor/controller & Power Board (late), 250mA (T.25A) 5 X 20 Slow Blow/Time Delay	\$2.00
F18	Fuse, 115/230 VAC, 1/8 amp, AGC 1/8, Power Board (early - with open fuse)	\$1.12
024-1	24 VAC 1" Solenoid Valve	\$65.00

VIII. LIMITED WARRANTY

All Myron L Company AQUASWITCH I Controllers & AQUASWITCH II Monitor/controllers and sensors have a Two Year Limited Warranty. If any AQUASWITCH or sensor fails to function normally, return the faulty unit to the factory prepaid. If, in the opinion of the factory, failure was due to materials or workmanship, repair or replacement will be made without charge.

A reasonable service charge will be made for diagnosis or repairs due to normal wear, abuse or tampering. Warranty is limited to the repair or replacement of Monitor/controller or sensor only. The Myron L Company assumes no other responsibility or liability.

MYRON L COMPANY
2450 Impala Drive
Carlsbad, CA 92010-7226
USA
Tel: 760-438-2021
Fax: 760-931-9189

www.myronl.com

Custom Monitors/controllers available, contact us with your special needs. Price and delivery upon request.

TERMS & CONDITIONS *(additional information available upon request)*

ALL SPECIAL ORDER ITEMS ARE NON-RETURNABLE AND NON-REFUNDABLE.

Minimum order \$25.00. All prices are US dollars and are F.O.B Carlsbad, CA. USA.

Terms: 1% 10 days, net 30 days upon approved credit.

Credit Cards Accepted: Visa, MasterCard and American Express

Because of our policy of continuous product improvement, the Myron L Company reserves the right to make changes in design, specifications, and prices without notice.

IX. GLOSSARY

442™	An Internationally recognized “natural water” standard developed by the Myron L Company in 1964.
Algorithm	A procedure for solving a mathematical problem. See Addendum, Temperature Compensation and TDS Derivation.
Anions	Negatively charged ions
DVM	Digital Volt Meter
Hysteresis	Dead Band — related to alarm set point. The amount of delay or overlap between change from high to low or low to high.
LCD	Liquid Crystal Display
KCl	Potassium Chloride — used as a standard for many applications. Normally, micromhos or microsiemens are the units of measure.
NaCl	Sodium Chloride — used as a standard for sea water and other applications.
NIST	National Institute Standards & Testing
PLC	Programmable Logic Controller
PPM	Parts Per Million — common units of measure for TDS.
PPT	Parts Per Thousand — common units of measure for TDS.
SCADA	Supervisory Control And Data Acquisition
Tempco (TC)	Temperature Compensation — See Addendum, Temperature Compensation.
TDS	Total Dissolved Solids or the Total Conductive Ions in a solution — normally displayed as ppm or ppt. See Addendum, Conductivity Conversion to TDS.
Tweaker	A screwdriver specially designed for adjusting electrical calibration controls.
µM or µS	Micromho or microsiemen — common unit of measure for conductivity.
Meg or Ωohm	Megohm — common unit of measurement for resistivity.
USP25	United States Pharmaceutical regulation, revision number 25. In part, requires Conductivity/TDS, resistivity or pH measurements be taken, recorded and/or

systems controlled using equipment without temperature compensation. Requires a separate temperature measuring device (temperature measurements may be part of Cond/TDS, Resistivity or pH device but must not correct measurements for temperature errors).

X. NOTES

XI. ADDENDUM

A. CONDUCTIVITY, TDS, RESISTIVITY and TEMPERATURE RELATIONSHIPS

1. TEMPERATURE COMPENSATION (Tempco) of Aqueous Solutions

Electrical conductivity indicates solution concentration and ionization of the dissolved material. Since temperature greatly affects ionization, conductivity measurements are temperature dependent and are normally corrected to read what they would be at 25°C.

a. Standardized to 25°C

Conductivity or Resistivity are accurately measured in the AQUASWITCH II by a method that ignores electrolysis, electrode characteristics, etc., and uses a unique circuit to perform temperature compensation. In simpler instruments, conductivity values are usually assigned an average correction similar to KCl solutions for correction to 25°C. The correction to an equivalent KCl solution is a standard set by chemists. It standardizes the measurements and allows calibration with precise KCl solutions recognized for stability.

b. Tempco Variation

Most conductivity instruments use an approximation of the temperature characteristics of solutions, perhaps even assuming a constant value. The value for KCl is often quoted simply as 2%/°C. In fact, KCl tempco varies with concentration and temperature in a non-linear fashion. Other solutions have more variation still. The AQUASWITCH II uses corrections that change with concentration and temperature instead of single average values. See Chart 1.

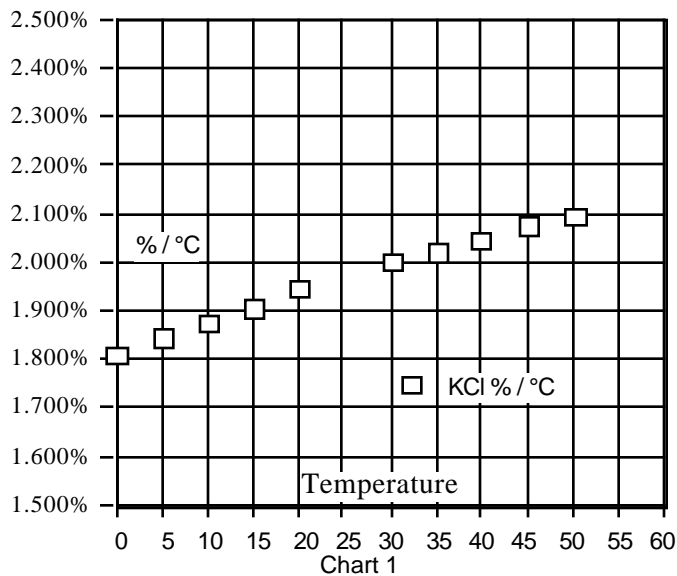

The AQUASWITCH II will provide the repeatability of data needed for relative values for process control.

2. CONDUCTIVITY CONVERSION to TOTAL DISSOLVED SOLIDS (TDS)

Electrical conductivity indicates solution concentration and ionization of the dissolved material. Since temperature greatly affects ionization, conductivity measurements are temperature dependent and are normally corrected to read what they would be at 25°C (ref. Temperature Compensation).

a. How it's Done

Once the effect of temperature is removed, the compensated conductivity is a function of the concentration (TDS). Temperature compensation of the conductivity of a solution is performed automatically by the electronic circuit, using data derived from chemical tables. Any dissolved salt at a known temperature has a known ratio of conductivity to concentration. Tables of conversion ratios referenced to 25°C have been published by chemists for decades.

b. Solution Characteristics

Real world applications have to measure a wide range of materials and mixtures of electrolyte solutions. To solve this problem, industrial users commonly use the characteristics of a standard material as a model for their solution, like the KCl favored by chemists for its stability.

Users dealing with sea water, etc., commonly use NaCl as the model for their concentration calculations. Users dealing with freshwater work with mixtures including sulfates, carbonates and chlorides, the three predominant components (anions) in freshwater that Myron L Company calls "natural water". These are modeled in a mixture called "442™" which the Myron L Company developed and markets for use as a calibration standard, as it does standard KCl and NaCl solutions.

c. When does it make a lot of difference?

First, the accuracy of temperature compensation to 25°C determines the accuracy of any TDS conversion. Assume we have industrial process water to be pretreated by RO. Assume it is 45°C and reads 1500 µS uncompensated.

1. If NaCl compensation is used, an instrument would report 1035 µS compensated, which corresponds to 510 ppm NaCl.
2. If 442 compensation is used, an instrument would report 1024 µS compensated, which corresponds to 713 ppm 442.

The difference in values is 40%.

In spite of such large error, some users will continue to take data in the NaCl mode because their previous data gathering and process monitoring was done with an older NaCl referenced device.

Those who want true TDS readings that will correspond to evaporated weight will select the correct Solution Type.

3. TEMPERATURE COMPENSATION (Tempco) and TDS DERIVATION

When making conductivity/resistivity measurements, the Solution Selection determines the characteristic assumed as the instrument reports what a measured conductivity or resistivity would be if it were at 25°C. The characteristic is represented by the tempco, expressed in %/°C. If a solution of 100 µS at 25°C increases to 122 µS at 35°C, then a 22% increase has happened over this change of 10°C. The solution is said to have a tempco of 2.2 %/°C.

Another solution would have a different tempco because of its ionization activity. And, that tempco may be a little different at a different concentration or temperature.

NOTE: Resistivity TEMPCO's change very drastically above 10M .

XI. ADDENDUM Continued

4. RESISTIVITY

Resistivity is the inverse of conductivity (the reverse is also true), i.e. $18.2 \text{ M} = 0.0549 \text{ } \mu\text{M}$ or μS , and $0.2 \text{ } \mu\text{M}/\mu\text{S} = 5 \text{ M}$.

MYRON L COMPANY
2450 Impala Drive
Carlsbad, CA 92010-7226
USA
Tel: 760-438-2021
Fax: 760-931-9189

www.myronl.com

Made in USA

ACCURACY • RELIABILITY • SIMPLICITY

MYRON L
COMPANY
Water Quality Instrumentation
Accuracy • Reliability • Simplicity