

## Installing Conductivity/TDS/Salinity/Resistivity Sensors

For use with Myron L® Company 900 Series Multi-Parameter Monitor/Controllers

Prior to installing the sensor, you should record the sensor model number and cell constant for your records, as they will be required when programming the 900. The cell constant is a 5 digit number preceded by “K=” located directly below the sensor model number on the label attached to the sensor cable. Example shown here is a CS951 with a cell constant of “**0.8506**”.

CS951  
K = **0.8506**  
PT1000  
S/N 181749-03

The sensor mounting orientation must provide a continuous and adequate flow of liquid to prevent air bubbles from being trapped within the sensor’s electrode area (CS951 shown below). Air bubbles will impair the sensor’s ability to function properly.

### A. Insertion Mode (in-line installation)

- Use Teflon tape as required (user supplied).
- Verify that the sensor fitting is assembled properly, as shown below.
- Insert the sensor fitting assembly into the “T” fitting with the electrode aligned as shown below and tightly secure.

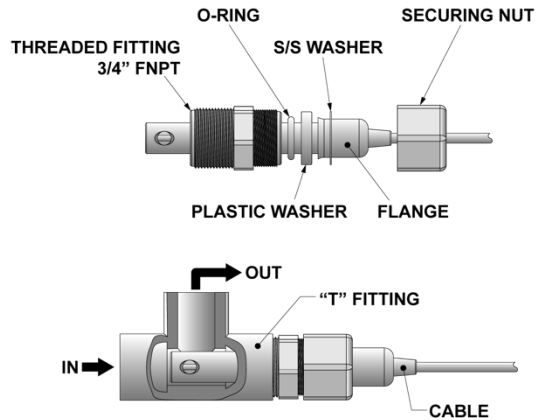

### B. Immersion or Dip Sensor Assembly

- Use Teflon tape as required (user supplied).
- Verify that the sensor fitting is assembled properly, as shown below.
- Insert and pull the sensor’s cable through the extension tube and then tightly attach extension tube to sensor assembly.

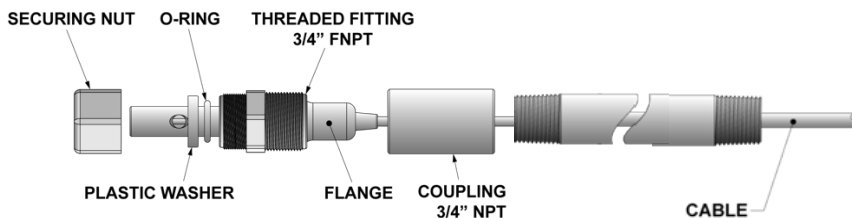

### C. Wiring Sensors

- The Terminal Block (TB) connector should be unplugged from the back of the 900 while attaching sensor wires.
- If routing the sensor cable through a conduit or strain relief, ALWAYS do that first, then attach the cable wires to the terminal block.

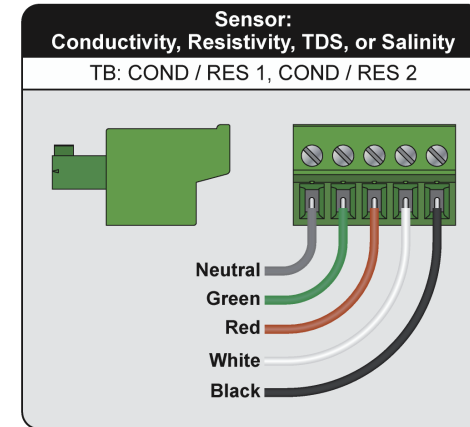

**NOTE:** It is suggested that the user mount watertight restraint fixtures and at least one service loop on all cabling. All cabling should be routed using best practices to protect from damage and/or electromagnetic interference (EMI). Consider grounded steel conduit for maximum protection. Signal cables should be routed separate from line power cables or any other source of interference.

### LIMITED WARRANTY

All Myron L® conductivity sensors have a Two (2) Year Limited Warranty. If the sensor fails to function normally, return the sensor to the factory prepaid. If, in the opinion of the factory, failure was due to materials or workmanship, repair or replacement will be made without charge. A reasonable service charge will be made for diagnosis or repairs due to normal wear, abuse or tampering. This Warranty is limited to the repair or replacement of the sensor only. The Myron L® Company assumes no other responsibility or liability.

### MYRON L® COMPANY

2450 Impala Drive – Carlsbad, CA 92010-7226 – Phone: +1-760-438-2021  
Customer Service: [info@myronl.com](mailto:info@myronl.com) – Technical Support: [techquestions@myronl.com](mailto:techquestions@myronl.com)  
Website: [www.myronl.com](http://www.myronl.com)

## Installing pH/ORP Sensors

For use with Myron L® Company 900 Series Multi-Parameter Monitor/Controllers

The sensor mounting orientation must provide a continuous and adequate flow of liquid to prevent air bubbles from being trapped within the sensor's electrode area. Air bubbles will impair the sensor's ability to function properly.

### A. Insertion Mode (in-line installation)

- Use Teflon tape as required (user supplied).
- Insert the sensor fitting assembly into the "T" fitting with the electrode aligned as shown below and tightly secure.

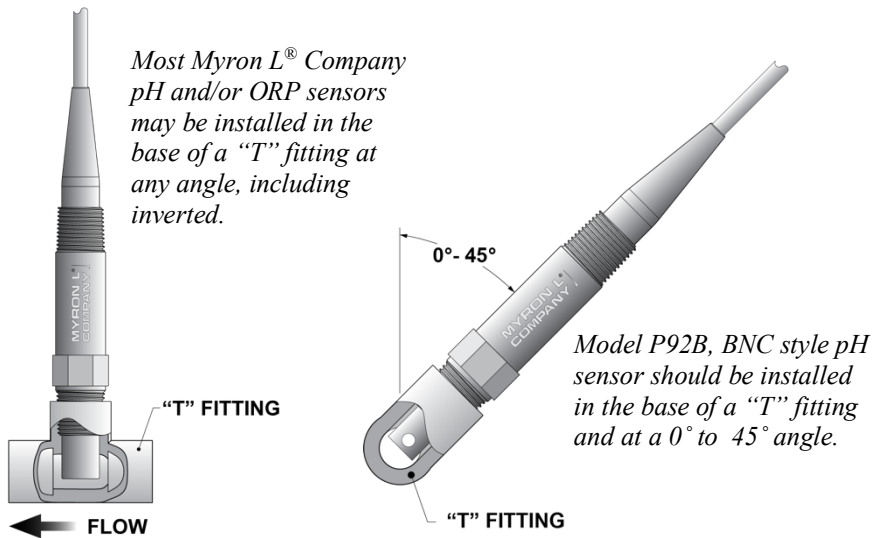

### B. Immersion or Dip Sensor Assembly

- Use Teflon tape as required (user supplied).
- Insert and pull the sensor's cable through the extension tube and then tightly attach extension tube to sensor assembly.

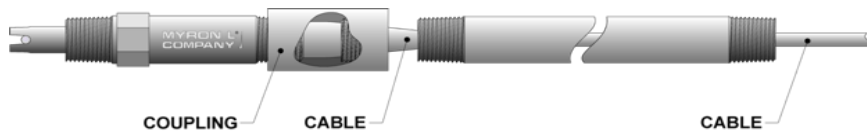

### C. Wiring MLC Pre-amplified Sensors

- The Terminal Block (TB) connector should be unplugged from the back of the 900 while attaching sensor wires.
- If routing the sensor cable through a conduit or strain relief, ALWAYS do that first, then attach the cable wires to the terminal block.

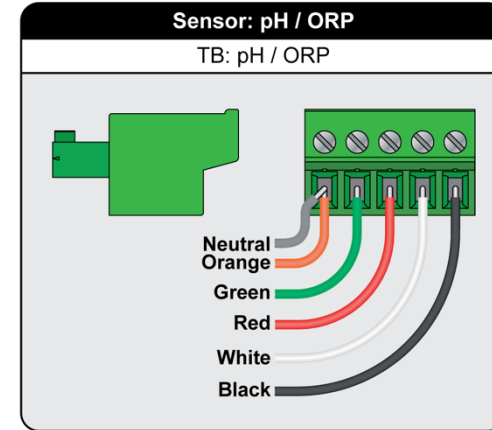

**NOTE:** It is suggested that the user mount watertight restraint fixtures and at least one service loop on all cabling. All cabling should be routed using best practices to protect from damage and/or electromagnetic interference (EMI). Consider grounded steel conduit for maximum protection. Signal cables should be routed separate from line power cables or any other source of interference.

### STORAGE/SHELF LIFE

ALL pH and ORP sensors have a limited lifespan. For this reason, it is recommended that extra sensors be kept on hand for all process applications. To obtain the maximum life, ALWAYS store sensors in Myron L® Company pH/ORP Sensor Storage Solution and in a cool location when not in use. DO NOT allow sensor to dry out. DO NOT allow sensor to freeze.

### LIMITED WARRANTY

All pH and ORP sensors have a six (6) month limited warranty. If any sensor fails during that time, return the failed sensor to the factory, prepaid. If, in the opinion of the factory, failure was due to materials or workmanship, repair or replacement will be made without charge. A reasonable service charge will be made for diagnosis or repairs due to normal wear, abuse or tampering. This Warranty is limited to the repair or replacement of the sensor only. The Myron L® Company assumes no other responsibility or liability.

### MYRON L® COMPANY

2450 Impala Drive – Carlsbad, CA 92010-7226 – Phone: +1-760-438-2021  
 Customer Service: info@myronl.com – Technical Support: techquestions@myronl.com  
 Website: www.myronl.com